

**CUSTOMER ASSISTANCE CENTER  
AUTHORIZED DEALERS**

**INSTRUCTION, USE AND MAINTENANCE MANUAL**

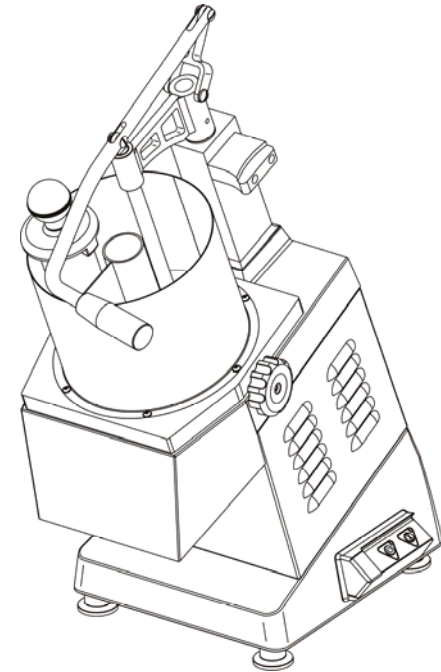

ed. 08/2018

**VEGETABLE CUTTER**

## INTRODUCTION

- This manual has been written to provide the customer with all information and relevant regulations about the machine, as well as use and maintenance instructions to ensure effective use so the machine will remain fully efficient over time.
- This manual must be given to people in charge of the use and periodic maintenance of this machine.

## TABLE OF CONTENTS

<b>CHAP. 1 - INFORMATION ABOUT THE MACHINE</b>	page 4
1.1 - GENERAL PRECAUTIONS	
1.2 - DESCRIPTION OF THE MACHINE	
1.2.1 - General description	
1.2.2 - Manufacturing characteristics (materials used)	
1.3 - SAFEGUARDS	
1.3.1 - General safeguards	
1.3.2 - Electrical safeguards	
1.4 - ACCESSORIES + UTENSILS	
1.4.1 - Accessories	
1.4.1.1 - Standard issue accessories	
1.4.1.2 - Non-standard issue accessories	
1.4.2 - Utensils	
<b>CHAP. 2 - TECHNICAL DATA</b>	page 11
2.1 - DIMENSIONS, WEIGHT, CHARACTERISTICS ...	
<b>CHAP. 3 - RECEIPT OF THE MACHINE</b>	page 13
3.1 - SHIPMENT OF THE MACHINE	
3.2 - CHECK PACKAGING AND ITS CONTENTS UPON RECEIPT	
3.3 - DISPOSAL OF PACKAGING	
<b>CHAP. 4 - INSTALLATION</b>	page 13
4.1 - PLACEMENT OF THE MACHINE	
4.1.1 - Collection bowl system	
4.1.2 - Chute system	
4.2 - POWER CONNECTION	
4.2.1 - TM-TG Food processor single-phase (230 V. 50 Hz)	
4.2.2 - TM-TG Food processor three-phase (400 V. 50 Hz)	
4.3 - FOOD PROCESSOR WIRING DIAGRAMS	
4.4 - TESTING	
<b>CHAP. 5 - USE</b>	page 17
5.1 - MOUNTING THE DISKS	
5.2 - LOADING AND CUTTING	

## CHAP. 8 - DISASSEMBLY

### **8.1 - OUT OF SERVICE**

If you decide to put the machine out of service for whatever reason, make sure it is unusable by any and all personnel:

⇒ **unplug and switch off the power supply.**

### **8.2 - WEEE Electronic-disposal, waste electrical and electronic equipment**



***In accordance with article 13 of Legislative Decree n. 151 of 25 July 2005, "Implementation of Directives 2002/95/CE, 2002/96/EC and 2003/108/EC, regarding the reduction of the use of hazardous substances in electric and electronic equipment, as well as waste disposal".***

*The symbol of the checked box on the equipment or the packaging indicates that the product must be disposed of separately, not with regular waste, at the end of the product's working life.*

*Recycling of this machine at the end of its working life is organized and carried out by the manufacturer. Any user who wishes to dispose of this machine must contact the manufacturer and follow the procedure that has been put in place for the recycling of the machine at the end of its working life.*

*Appropriate collection of the machine for recycling and environmentally safe disposal contributes to avoiding possible harm to health and the environment and favors reuse and/or recycling of the material the machine is made of.*

*Illegal disposal of the machine by the holder will be penalized by the administrative sanctions provided for by law.*

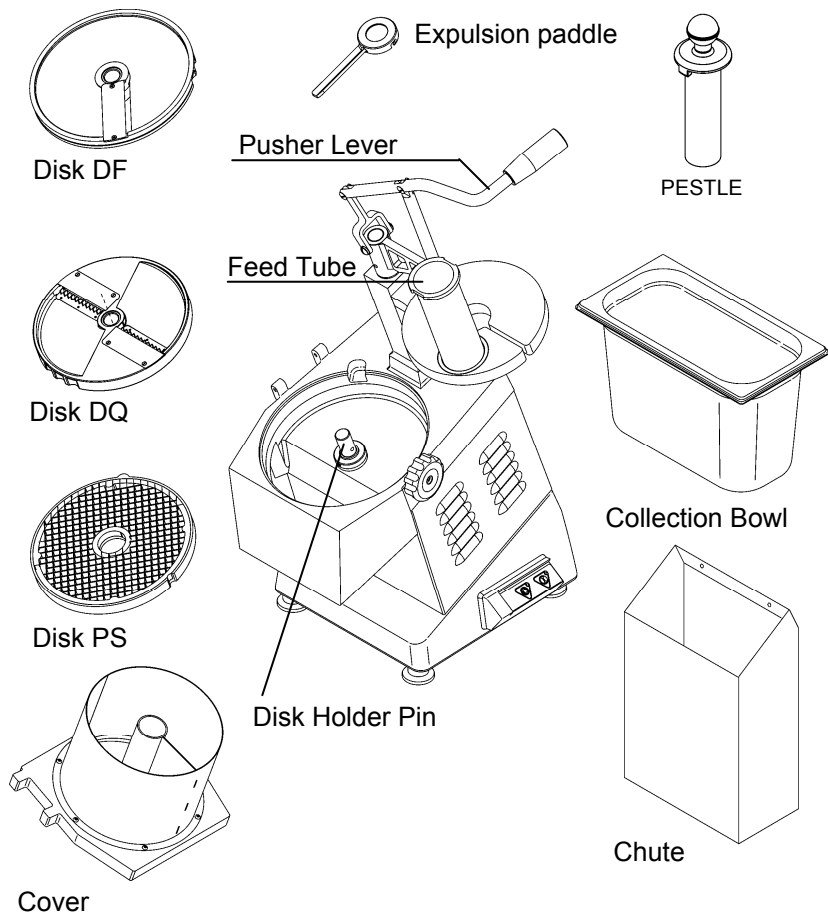

Fig. n°29 - View of the machine disassembled for cleaning

## CHAP. 6 - MAINTENANCE AND TIPS

page 19

- 6.1 - GENERAL
- 6.1.1 - Belt
- 6.1.2 - Feet
- 6.1.3 - Control panel label
- 6.1.4 - Power cable
- 6.1.5 - Disks
- 6.2 - WHAT TO DO IF...
- 6.2.1 - The disk clamp is defective
- 6.2.2 - The cover does not lock
- 6.2.3 - The food item is not cut well
- 6.2.4 - The food item has difficulty being expelled or is cut incorrectly
- 6.2.5 - The machine blocks
- 6.2.6 - The micro-switch on the pusher lever and cover do not work
- 6.2.7 - The machine does not turn on

## CHAP. 7 - CLEANING

page 21

- 7.1 - GENERAL
- 7.2 - PRODUCTS TO USE
- 7.3 - STEPS TO FOLLOW

## CHAP. 8 - DISASSEMBLY

page 23

- 8.1 - OUT OF SERVICE
- 8.2 - WEEE Electronic-disposal, waste electrical and electronic equipment

## **CHAP. 1 - INFORMATION ABOUT THE MACHINE**

### **1.1 - GENERAL PRECAUTIONS**

- The food processor must only be used by personnel trained in its usage and who are perfectly familiar with all of the safety regulations contained in this manual.
- In the event that personnel alternate, provide sufficient time for training.
- Even if safeguards are installed on the machine, avoid putting hands close to the moving parts.
- Before carrying out any cleaning or maintenance procedures, completely detach the power cord from the power supply.
- When cleaning or performing maintenance on the Food processor (in which case the safeguards have been removed), pay extreme attention to the residual risks of injury.
- During maintenance and cleaning, concentrate only on the task at hand.
- Frequently check to state of the power cord. A worn out or damaged cord is extremely dangerous, as it can lead to electrical injury.
- If the machine malfunctions or does not function well, do not use it. Contact the "Customer Assistance Center"; the contact information for which is located on the back of this manual.
- Do not use the Food processor on frozen products or on meat and fish with bones or on any non-food products.
- Do not attempt to repair the machine yourself, but contact the authorized "Customer Assistance Center".
- Always use the large pusher with the small removable pusher to cut the food items.
- To avoid problems, never overfill the feed tube and never push with excessive force.
- The manufacturer shall not be held in any way liable in the following cases:
  - ⇒ unauthorized personnel tamper with the machine;
  - ⇒ components are replaced with **non-original parts and disks not supplied by us**;
  - ⇒ the instructions in this manual are not **carefully** followed;
  - ⇒ inappropriate materials are used on the machine's surfaces.

breakers for the machine are inserted .

## **CHAP. 7 - CLEANING THE MACHINE**

### **7.1 - GENERAL**

- Cleaning the machine should be done once per day or, if necessary, more frequently.
- Cleaning all parts of the machine which come into direct or indirect contact with food must be done scrupulously.

**Before carrying out any operation, it is necessary to:**

⇒ detach the power cord from the power supply to completely separate the machine from the electrical system;

**Pay careful attention to the residual risks caused by the cutting components and/or barbs during the cleaning or handling of the disks.**

**WARNING!**

### **7.2 - PRODUCTS TO USE**

The machine must be washed with normal detergent at room temperature, using a wet cloth.

The machine must not be cleaned with a pressure jet cleaner. Do not use utensils, brushes, etc., because they can damage the surface of the machine.

**N.B. DO NOT PLACE ANY OF THE PARTS IN A DISHWASHER.**

### **7.3 - STEPS TO FOLLOW (Fig.n°29)**

**Disconnect the machine's power cord.**

Remove the cover and all the disks, the paddle, the small removable pusher, the collection bowl and/or chute.

Thoroughly clean the inside of the outlet, all the processing area and the disk holder pin.

Clean all external surfaces of the machine and the larger pusher. Dry with a cloth and reassemble the machine.

### 6.1.4 - Power cable

Periodically check the wear and tear of the power cord and if necessary, call the "Customer Assistance Center" to replace it.

### 6.1.5 - Disks

With use, the blade can deteriorate.

For disks DTV, DT 2, 3, 4, 7, 9 and PS 6, 8, 10, 20; purchase new disks.

For disks DF 1, 2, 3, 4, 5, 8, 10, 14 and DQ 4, 6, 8, 10, the blades can be replaced.

In that event, call the "Customer Assistance Center" and specify the exact disk code.

## 6.2 - WHAT TO DO IF...

### 6.2.1 - The disk clamp is defective:

Check that the disks and the disk holder pin are clean.

### 6.2.2 - The cover does not lock:

Check that the cover is clean and correctly placed.

### 6.2.3 - The food item is not cut well:

Check the wear of the blades.

### 6.2.4 - The food item has difficulty being expelled or is cut incorrectly:

Check that the expulsion paddle has been mounted together with disk blades DT (the entire series), DF 1, 2, 3, 4 and DQ 4; that the collection bowl is not full and that the outlet is not clogged.

### 6.2.5 - The machine blocks:

Make sure the food item to be processed is not frozen or too hard and that the electric current is the one specified on the technical data plate (Fig. n° 19).

### 6.2.6 - The micro-switch on the pusher lever and cover do not work:

Check that they are not blocked by build-up or other items.

### 6.2.7 - The machine does not turn on:

Check that all the safeguards are in the correct place (Chapter "Safeguards" 1.3); that the plug is solidly in the socket and all the circuit

## 1.2 - DESCRIPTION OF THE MACHINE

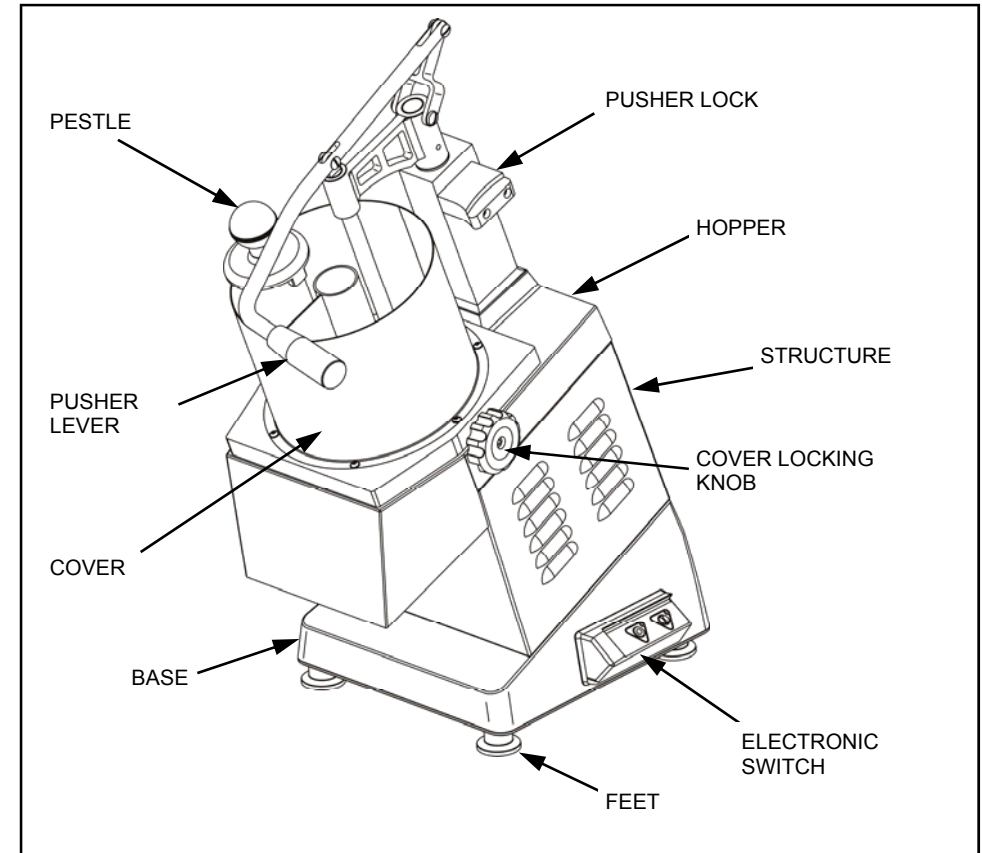

FIG. n°1 - General image of food processor mod. "TM-TG"

### 1.2.1 - General description

The TM-TG Food processor was designed and built for the specific purpose of slicing vegetables, fruit and mozzarella, guaranteeing:

- maximum safety during use, cleaning and maintenance;
- maximum hygiene, thanks to careful selection of the materials and to the elimination of rough edges on parts of the machine which will come in contact with the food, thereby enabling easy total cleaning and disassembly;
- all components are stable and sturdy;
- low noise emissions thanks to the belt transmission;
- easy to handle.

### 1.2.2 - Manufacturing characteristics (materials used)

The **TM-TG** Food processor is built of materials extremely resistant to mechanical wear and tear, structural shock, corrosive agents normally found in food items.

Specifically:

- The work bowl and base are in polished aluminum, while the base cover is in anodized aluminum. This guarantees hygienic contact with the food and resistance to acids, salts and oxidation.
- Motor cover, cover, pusher lever, disk holding stem are in AISI 304 or 430 steel.
- Small removable pusher, permanently mounted large pusher, collection bowl, mobile control box in high resistance plastic, perfect for contact with food items.
- The processing blade disks are:
  - a) DF, DQ and PS series have the substructure in aluminum and the blades in AISI 420.

### 1.3 - SAFEGUARDS

#### 1.3.1 - General safeguards

Regarding mechanical, electrical, hygienic/health safeguards, the TM-TG Food processor described in this manual is in accordance with directives:

**MECHANICAL SAFEGUARDS:** 2006/42.

**ELECTRICAL SAFEGUARDS:** 2006/95/CEE; 2004/108/CEE.

**HYGENIC SAFEGUARDS:** Regulation 1935/2004.

\*\* The food processor is equipped with the electrical and mechanical safety measures during the operational, cleaning and maintenance phases as prescribed by law. **RESIDUAL RISKS** still exist which are impossible to completely eliminate. In this manual they are identified with **WARNING**.

These refer to the risk of cuts caused by handling the disks during their replacement and/or cleaning.

#### 1.3.2 - Electrical safeguards

The Food processor TM-TG is equipped with sensors:

- A on the pusher lever, to turn off and block the machine if the lever is raised over the mouth of the cover and rotated counter-clockwise. This sensor will cause the machine to **automatically start up** as soon as the lever is placed in the correct working position (*Fig. n°2*).

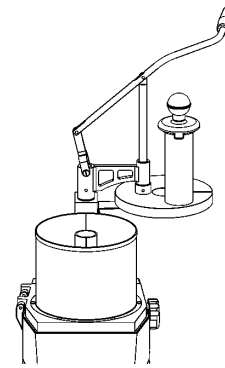

Fig. n°26  
Resting position

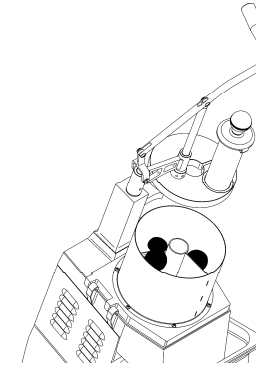

Fig. n°27  
Product loaded into the  
work bowl/hopper

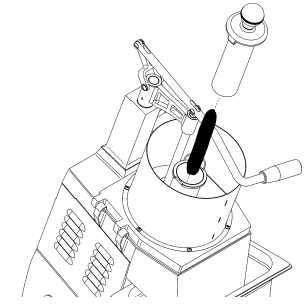

Fig. n°28  
Product loaded into the feed  
tube on the lever.

instructed in point **5.1 "A"**. After doing so, an electronic system will prevent the machine from automatically starting up again; the machine will start when the "I" button is pushed.

- D If using the collection bowl, empty its contents every 2-3 processing cycles. Using the machine when the collection bowl is too full could prevent correct expulsion of the food and cause an improper cut, block the machine or cause motor to break down.

## **CHAP. 6 - MAINTENANCE AND TIPS**

### 6.1 - GENERAL

Before carrying out any operation, it is necessary to:

Detach the power cord from the power supply to completely separate the machine from the electrical system;

#### 6.1.1 - Belt

The belt does not require any adjustment. Generally after 3-4 years it must be replaced. If it breaks, call the "Customer Assistance Center".

#### 6.1.2 - Feet

Over time the feet can deteriorate and lose their elasticity, which will decrease the stability of the machine. Proceed with their substitution.

#### 6.1.3 - Control panel label

Over time the pushbutton label may become stained and/or damaged. Call the "Customer Assistance Center" to replace it.

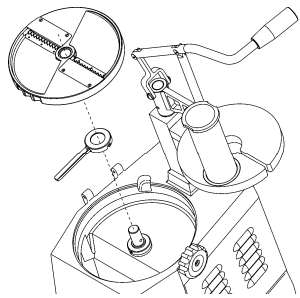

Fig. n°23 - Assembly of expulsion paddle

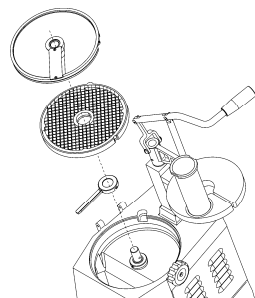

Fig. n°24 - Assembly of coupled discs PS- DF

## 5.2 - LOADING AND CUTTING

### WARNING!

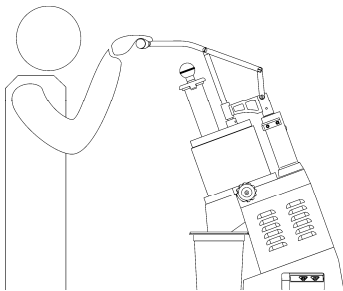

Fig. n°25 - Posizione corretta.

Stand properly in order to operate the machine without incident. Your body must be perpendicular to the work plane (see Fig. n°25). **Do not position your body in such a way that any part comes into direct contact with moving parts of the machine.**

**N.B.** The food items to be processed must be loaded into the TM TG when the motor is off.

The steps are the following:

- A Put the large pusher in the resting position (as in Fig. n°26). Load the food items in the mouth of the cover (as in Fig. n°27). If the food items are small (like carrots, zucchini, etc.) insert them into the feed tube with the small removable pusher (as in Fig. n°28). Turn the pusher lever to the working position and turn on the machine. Assist the food processing with light pressure on the pusher lever or, when using the small removable pusher light pressure with it in the feed tube.
- B Once the food items have all been processed, lift the pusher lever and turn it into the resting position. A safeguard system will prevent the machine from working. Load more food items and replace the pusher lever in the working position. The machine will automatically start up again.
- C To substitute the disk and change the type of processing, do as

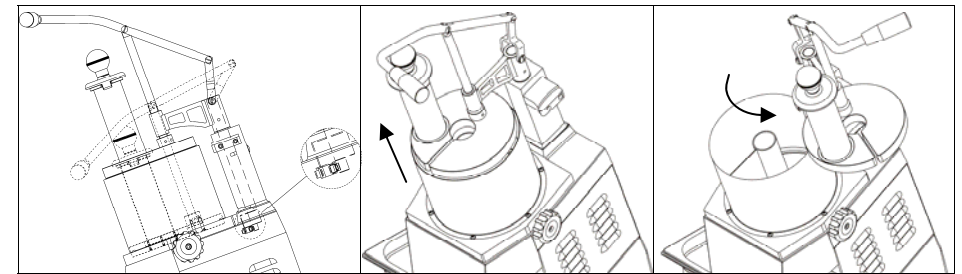

Fig. n°2 - Location of electrical safeguards

- B on the work bowl, to block the machine from working if the cover is removed (to replace the disks, for example) (Fig. n°3A), and allows for the machine to be **manually switched on** (pushing the "I" button) only if the cover is in the closed position, correctly locked with the locking knob (Fig. n°3).

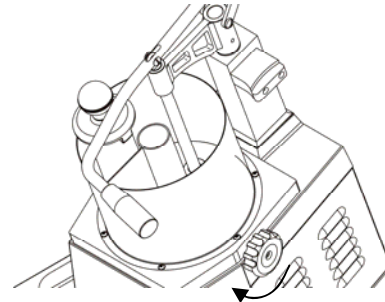

Fig. n°3 - Location of mechanical safeguards

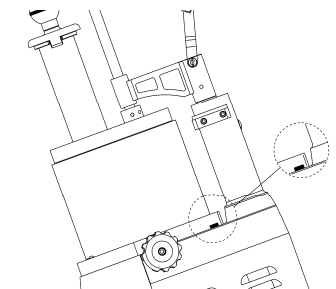

Fig. n°3A - Location of electrical safeguards

- C on the motor cover, to block the machine from working if the collection bowl or chute are not placed correctly on the outlet, and allows for the machine to be **manually switched on** (pushing the "I" button) only if the bowl or chute are placed correctly (Fig. n°4).

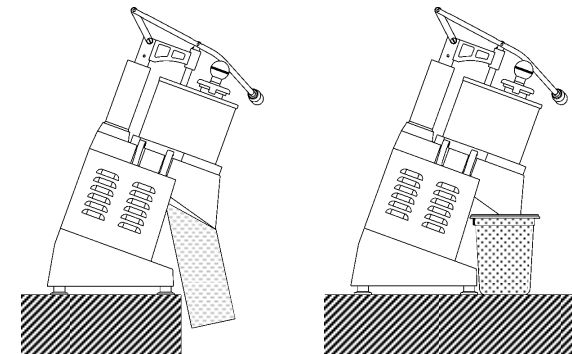

Fig. n°4 - Placement of the chute or collecting bowl to permit start up

The TM-TG Food processor is also equipped with a control panel composed of:

- D an IP 54 insulated control box using low voltage made up of two pushbuttons; to turn on "I" and to turn off "O" the machine (Fig. n°5).

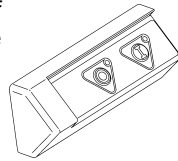

Fig. n°5 - Machine on - off diagram

- E an IP X3 insulated power board made up of a transformer and two standard relays controlled by a control board, and of sensors on the collection bowl, chute and cover; to turn the machine on and off.

The TM-TG Food processor is equipped with an N.V.R. system in the event of voltage return, after a previous fall in voltage, which allows the machine to be switched on only by using the "I" button.

## 1.4 - ACCESSORIES + UTENSILS

### 1.4.1 - Accessories

The TM-TG Food processor is equipped with many accessories. Some are standard issue; others must be specifically requested by the Customer.

#### 1.4.1.1 - Standard issue accessories

**Small Removable Pusher:** in food-grade polyethylene, helps when cutting small food items, inserted into the feed tube on the large pusher (Fig. n°6).

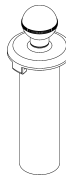

Fig. n°6 - Small removable pusher - vegetables

**Collection bowl:** in food-grade polyethylene, in "GASTRONORM" dimension 1/3, h=200; equipped with a magnetic sensor (Fig. n°7).

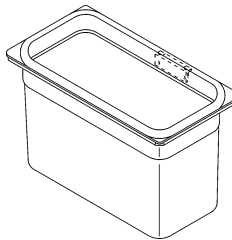

Fig. n°7 - Collection bowl with magnetic sensor

**Expulsion Paddle:** in AISI 304 steel, mounted on the blade holder pin. Helps the expulsion of the sliced food product. Usable only with disk blades DTV, DT2 - 3 - 4 - 7 - 9, DF1 - 2 - 3 - 4 (Fig. n°9).

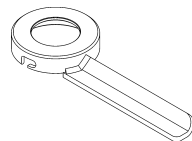

Fig. n°8 - Expulsion paddle

## 4.4 - TESTING

**Test the machine several times by following these steps:**

- a) Push the on button "I" and the off button "O" and check that the corresponding LED lights turn on and off as well (Fig. n°22).
- b) Check that the motor turns off and then turns on by rotating the pusher lever first into the resting position and then toward the cover .
- c) Check that the machine turns off when the cover is removed and that it starts up again only after the cover has been correctly replaced and the START "I" button has been pushed.
- d) Check as in point "c" above but with the collection bowl or with the chute.

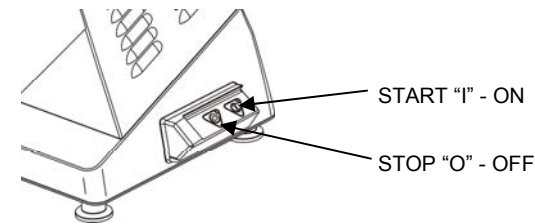

Fig. n°22 - Power switch.

## CHAP. 5 - USE

**WARNING!**

### 5.1 - MOUNTING THE DISKS

- A. The expulsion paddle must be mounted on the disk holder pin before every other disk (as in Fig. n°23-24). After assembling it, do the following.
- B. Choose the desired disk from among DF 1-2-3-4-5-8-10-14, DTV, DT 2 -3-4-7-9, or DQ 4-6-8-10; after removing the aluminum cover, place the paddle on the disk holding stem and then put the disk on (Fig.n°23). Make it rotate normally until it is completely attached. Replace the aluminum cover and lock it with the knob.
- C. (FOR CUBING) (Fig.n°24)  
Choose the pair of disks desired from among PS8-DF8, PS10-DF10, PS14-DF14, PS20-DF14. Insert the paddle, then the first PS disk with the notch towards the right, with the machine in front of you. Afterward, put on the DF disk as described in point "B" above (see Fig. n°24).

**NB: THE EXPULSION PADDLE MUST BE MOUNTED WHEN USING THE ANY OF THE DISKS.**



### 4.3 - WIRING DIAGRAMS

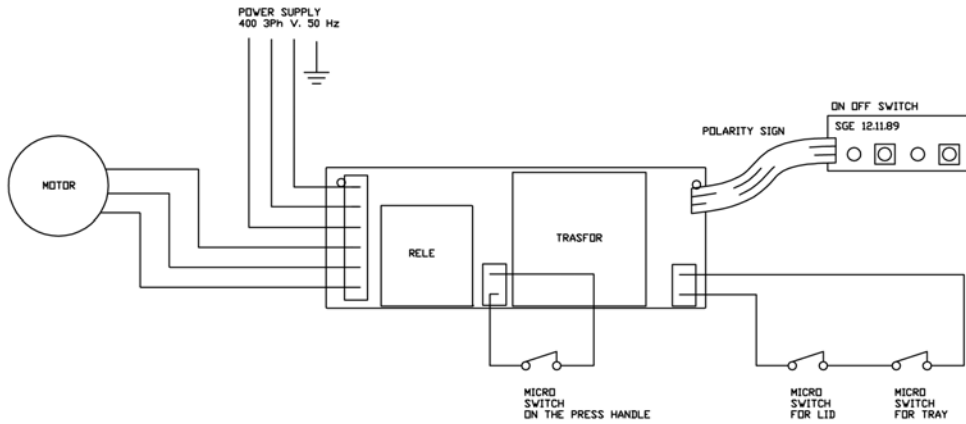

Fig. n°21 - Three-phase 230/400 Volt electrical system diagram

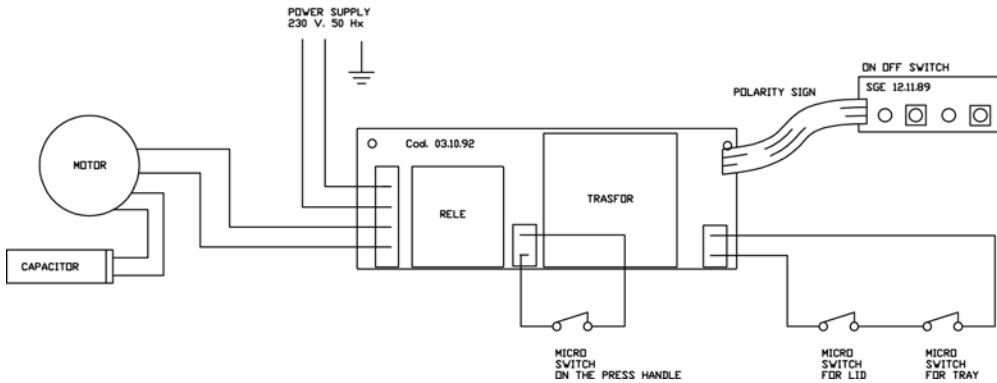

Fig. n°21-A - Mono-phase 230 Volt electrical system diagram

### 1.4.1.2 - Non-standard issue accessories

**Chute:** in AISI 304 steel, instead of the collection bowl, helps the processed food fall into a receptacle usually placed at the bottom of the work station (Fig. n°9).

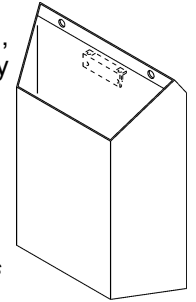

Fig. n°9 - Chute directing food item downwards

**Disk Blade Holder:** in plastic-coated steel, it is a useful disk container (Fig.n°10).

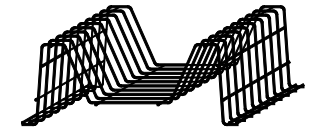

Fig. n°10 - Disk blade holder

### 1.4.2 - Utensils

The TM-TG Food processor can be, upon request, outfitted with various types of disks for different types of processing.

#### **SLICING DISK BLADES "DF":**

The substructure is in aluminum and the blades in AISI 420.

These disk blades are available:

- DF1
- DF2
- DF3
- DF4
- DF5 specifically for tomatoes and bell peppers
- FD8
- DF10
- DF14

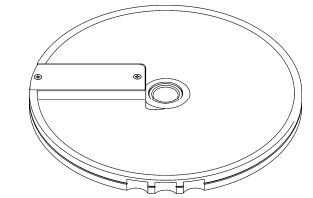

Fig. n°11 - Utensils "DF" type

**- DISK BLADES FOR SHREDDING "DT":**

The substructure is in aluminum, while the body of the disk is in AISI 420.

These disk blades are available:

- DTV** for grating
- DT2**
- DT3**
- DT4**
- DT7**
- DT9** specifically for mozzarella

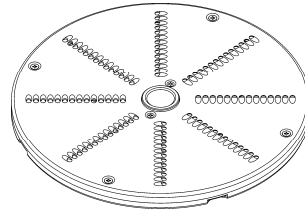

Fig. n°12 - Utensils "DT" type

**- DISK BLADES FOR STICKS "DQ":**

The substructure is in aluminum and the blades in AISI 420.

These disk blades are available:

- DQ4**
- DQ6**
- DQ8**
- DQ10**

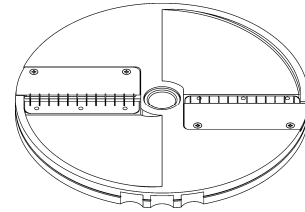

Fig. n°13 - Utensils "DQ" type

**- DISK BLADES FOR CUBING "PS G":**

The substructure is in aluminum and the blades in AISI 420.

These disk blades are available:

- |                           |             |
|---------------------------|-------------|
| <b>PS8 G</b> coupled with | <b>DF8</b>  |
| <b>PS10 G</b>             | <b>DF10</b> |
| <b>PS14 G</b>             | <b>DF14</b> |
| <b>PS20 G</b>             | <b>DF14</b> |

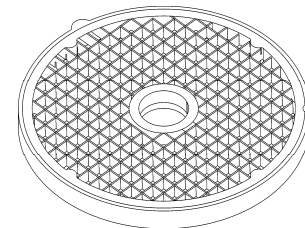

Fig. n°14 - Utensils "PS G" type

**4.2.2 - TM-TG Food processor three-phase (400 V. 50 Hz)**

The TM-TG Food processor is equipped with a power cord with a 5x1 mm<sup>2</sup> cross section, 1.5 m long.

Connect the Food processor to the three-phase current 400 Volt 50 Hz by using a **red CEI** plug, using a 10A differential magnetothermal switch,  $\Delta I = 0.03$  A.

Make sure that the grounding system functions perfectly at this point.

Also check that the information on that data plate (Fig. n°19) corresponds with the information on the delivery and companion documents.

Before definitively connecting the machine to the induction motor power supply, check the direction that the disks are rotating (for assembly see chapter 5.1) by quickly pushing the on button "I" and then immediately pushing the off button "O".

The blade disk must turn counter-clockwise looking at the disks from the hole on the larger pusher (Fig. n°20).

If the disks are not turning correctly, invert (in the plug or the power outlet) two of the three wires (black and gray).

The induction motors mounted on the Food processor can work with both a 230V three-phase current and a 400 V three-phase current.

Unless otherwise specified, the connections are for a 400 V current; to adapt to a 230 V three-phase current, request assistance from "**CUSTOMER ASSISTANCE**".

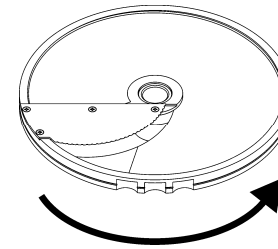

Fig. n°20 - Direction of disk rotation

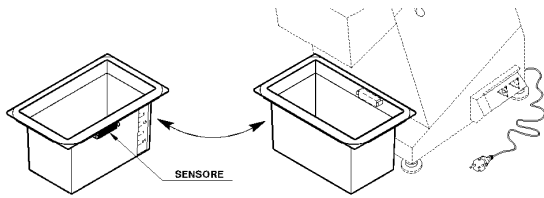

Fig. n°17 - Collection bowl system

#### 4.1.2 - Chute system

If the TM-TG Food processor is equipped with a chute, attach it below the outlet (Fig. n°18).

#### **NB. Correct assembly:**

Place the screws over the holes in the chute and tighten until the chute moves downward and the screws are completely inserted.

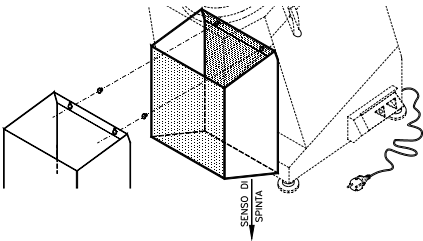

Fig. n°18 - Chute system

### 4.2 - POWER CONNECTION

#### 4.2.1 - TM-TG Food processor single-phase (230 V. 50 Hz)

The TM-TG Food processor is equipped with a power cord with a 3x1 mm<sup>2</sup> cross section, 1.5 m long and a "SHUKO" plug.

Connect the Food processor to the single-phase current 230 Volt 50 Hz, using a 10A differential magnetothermal switch,  $\Delta I = 0.03A$ .

Make sure that the grounding system functions perfectly at this point.

Also check that the information on that data plate (Fig. n°19) corresponds with the information on the delivery and companion documents.

Fig. n°19 - Technical data plate

Mod.	_____
Matr.	_____ Watt.
	_____ H.p. _____ A. _____ Hz.
○	_____ ~ Volts. _____ Kg. ○
Anno	_____

Fig. n°19 - Targa tecnica - matricola

## CHAP. 2 - TECHNICAL DATA

### 2.1 - DIMENSIONS, WEIGHT, CHARACTERISTICS ...

Fig. n°15 - Maximum dimensions

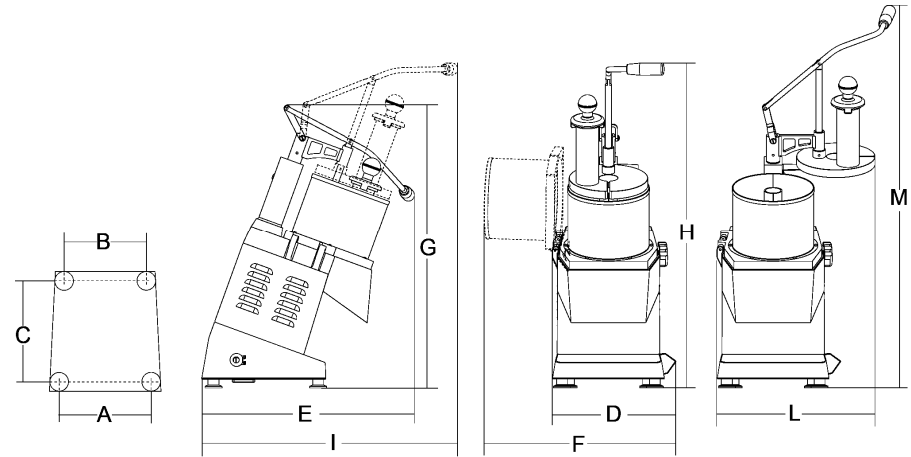

	u.m.	TM-TG
<b>Current</b>	2ph 3ph	230 V./ 50 Hz 230-400 V./ 50 Hz
<b>Power</b>	watt / Hp	515 / 0.7
<b>Disk evolutions</b>	r.p.m.	300
<b>A x B x C</b>	mm	225 x 195 x 255
<b>D x E x G</b>	mm	296 x 509 x 676
<b>F x I x H</b>	mm	460 x 612 x 777
<b>L / M</b>		428 / 915
<b>Net weight</b>	kg	20
<b>Noise level</b>	dB	≤70

The electrical specifications of this machine are indicated on a data plate on the back of the machine. Before plugging it in, see **4.2 - POWER CONNECTION**.

## **CHAP. 3 - RECEIPT OF THE MACHINE**

### **3.1 - SHIPMENT OF THE MACHINE** (see Fig. n°16)

The TM-TG Food processor leaves our warehouses carefully and correctly packaged. The packaging includes:

- a) external box in thick cardboard;
- b) the machine;
- c) packing inserts to stabilize the machine inside the box;
- d) collection bowl;
- e) small removable pusher;
- f) expulsion paddle;
- g) this manual;
- h) **CE** conformity certification.

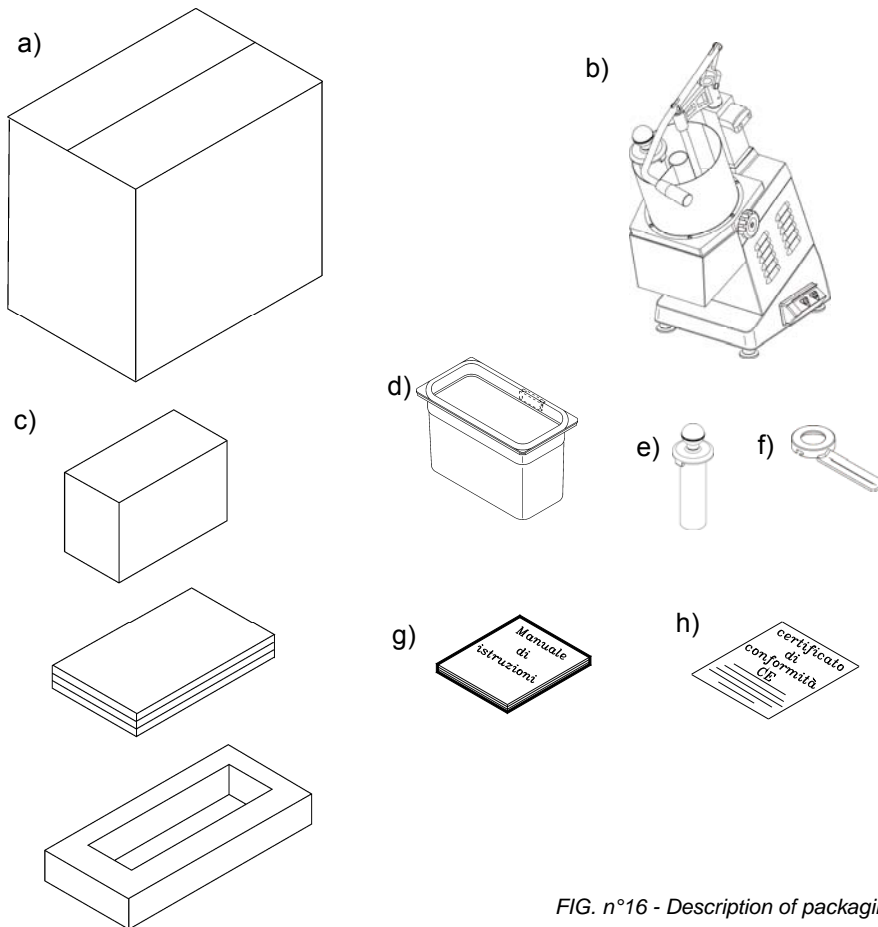

FIG. n°16 - Description of packaging

### **3.2 - CHECK PACKAGING AND ITS CONTENTS UPON RECEIPT**

Upon receipt of the package containing the TM-TG Food processor, all packaging and equipment should be thoroughly examined for shipping damage.

If the package shows external signs of damage upon receipt, any claim for loss or damage must be made to the carrier. Obvious loss or damage must be noted on the freight bill or express receipt. Within 3 days of the date indicated on the delivery documents, file a complete report regarding any damage the machine may have suffered. **DO NOT PLACE THE PACKAGE UPSIDE DOWN!!** During transport, make sure to hold the package solidly by the 4 corners (keeping it parallel to the ground).

### **3.3 - DISPOSAL OF PACKAGING**

The packaging materials (cardboard, pallets, plastic straps and polyurethane chips) can be collected and disposed of by regular urban waste management companies, so their disposal can be easily handled.

If the machine is installed in a country with specific regulations, dispose of the packaging in accordance with the current practices prescribed by law.

## **CHAP. 4 - INSTALLATION**

### **4.1 - PLACEMENT OF THE MACHINE**

The surface on which the Food processor is installed must have the dimensions indicated in Fig.n°15, (i.e. sufficiently ample surface space); it must be level, dry, smooth, sturdy, stable and at least 80cm above the ground. As well, the machine must be in a non-saline environment with maximum 75% humidity and temperature of between +5°C and +35°C; in general, in environments which will not lead to the machine's malfunction.

#### **4.1.1 - Collection bowl system**

If the TM-TG Food processor is equipped with a collection bowl, attach it below the outlet so that it adequately covers the entire expulsion area, with the magnetic sensor facing the inside of the machine (Fig. n°17).