

10KG



120198

Bartscher GmbH
Franz-Kleine-Str. 28
D-33154 Salzkotten
Germany

Phone: +49 5258 971-0

Fax: +49 5258 971-120

Technical Support Hotline: +49 5258 971-197

www.bartscher.com



Version: 1.0

Date of preparation: 2022-01-14

Original instruction manual

1	Safety	2
1.1	Explanation of Signal Words.....	2
1.2	Safety instructions.....	3
1.3	Intended Use	5
1.4	Unintended Use	5
2	General information	6
2.1	Liability and Warranty	6
2.2	Copyright Protection	6
2.3	Declaration of Conformity	6
3	Transport, Packaging and Storage	7
3.1	Delivery Check.....	7
3.2	Packaging	7
3.3	Storage	7
4	Technical Data.....	8
4.1	List of Components of the Appliance	8
4.2	Technical Specifications	10
4.3	Functions of the Appliance.....	11
5	Installation and operation	12
5.1	Installation.....	12
5.2	Operation	15
6	Cleaning and Maintenance	17
6.1	Safety Instructions for Cleaning	17
6.2	Cleaning.....	17
6.3	Maintenance	18
7	Disposal.....	18



Read this instruction manual before using and keep it available at all times!

This instruction manual contains information about installation, operation and maintenance of the appliance and constitutes an important source of information and reference guide. The knowledge of all operational and safety instructions included in this manual is a prerequisite for safe and proper handling of the appliance. Additionally, accident prevention, occupational health and safety, and legal regulations in force in the area the appliance is used apply.

Before you start using the appliance, especially before turning it on, read this instruction manual in order to avoid personal injuries and property damages. Improper use may cause damage.

This instruction manual forms an integral part of the product and must be stored in an immediate vicinity of the appliance and be available at all times. The instruction manual should be transferred together with the appliance.

1 Safety

EN

This appliance has been manufactured in accordance with technical standards currently in force. However, the appliance may be a source of hazards if used improperly or contrary to its intended purpose. All persons using the appliance must consider information included in this instruction manual and observe safety instructions.

1.1 Explanation of Signal Words

Important safety instructions and warning information are indicated in this instruction manual with appropriate signal words. You must strictly follow the instructions, to prevent accidents, personal injuries and property damages.



DANGER!

The signal word **DANGER** warns against hazards that lead to severe injuries or death if the hazards are not avoided.



WARNING!

The signal word **WARNING** warns against hazards that may lead to moderate or severe injuries or death if the hazards are not avoided.



CAUTION!

The signal word **CAUTION** warns against hazards that may lead to light or moderate injuries if the hazards are not avoided.

IMPORTANT!

The signal word **IMPORTANT** indicates possible property damages, which may occur if safety instructions are not observed.

NOTE!

The symbol **NOTE** indicates subsequent information and guidelines for the user on usage of the appliance.

1.2 Safety instructions

Electrical Current

- Too high a mains voltage or incorrect installation may cause electric shock.
- The appliance may be connected only if data on the rating plate correspond with the mains voltage.
- To avoid short-circuit, the appliance should be kept dry.
- If there are malfunctions during operation, disconnect the appliance from the power supply.
- Do not touch the appliance's plug with wet hands.
- Never take hold of the appliance if it has fallen into water. Immediately disconnect the appliance from the power supply.
- Any repairs or housing opening may be carried out by professionals and relevant workshops only.
- Do not transport the appliance, holding it by the power cord.
- Do not allow the power cord to come into contact with heat sources or sharp edges.
- Do not bend, pinch nor knot the power cord.

- Always completely unwind the power cord.
- Never place the appliance or other objects on the power cord.
- Always take hold of the plug to disconnect the appliance from the power supply.
- Check the power cord regularly for damage. Do not use the appliance if the power cord is damaged. If this cable is damaged, it must be replaced by customer service or a qualified electrician in order to avoid dangers.

Operating Personnel

- The appliance may only be operated by qualified personnel and trained specialist personnel.
- This appliance may not be operated by persons (including children) with limited physical, sensory or mental capabilities, nor by persons with limited experience and/or limited knowledge.
- Children should be supervised to ensure that they are not playing with or switching on the appliance.

Supervised Usage only

- Only supervised appliance may be used.
- Always remain in an immediate vicinity of the appliance.

EN

Improper Use

- Unintended or prohibited use may cause damage to the appliance.
- The appliance may only be used when its technical condition is flawless and allows for safe operation.
- The appliance may only be used when all connections are executed according to rules of law in force.
- The appliance may only be used when it is clean.
- Use only original spare parts. Never attempt to repair the appliance on your own.
- Do not introduce any changes in the appliance nor modify it.

1.3 Intended Use

As described below, every use of the appliance for a purpose differing and/or diverging from its intended standard use, is prohibited and considered to be an unintended use.

The following is an intended use:

- Peeling potatoes.

1.4 Unintended Use

An unintended use may lead to personal injuries or property damages caused by hazardous voltage, fire or high temperature. The appliance may only be used to perform tasks described in this instruction manual.

The following is an unintended use:

- Peeling other vegetables and fruit,
- Removing clam shells and fish scales.

2 General information

2.1 Liability and Warranty

All information and instructions in this instruction manual account for legal regulations in force, current level of technical engineering knowledge as well as our expertise and experience, developed over the years. If special models or additional options are ordered, or state-of-the-art technical solutions were implemented, the actual scope of delivery of the appliance may, in some circumstances, differ from descriptions and numerous drawings in this instruction manual.

The manufacturer is not liable for any damages nor faults stemming from:

- failure to observe instructions,
- unintended use,
- technical alterations introduced by the user,
- usage of unapproved spare parts.

We reserve the right to introduce technical modifications to the product, intended for improvement of the appliance and its performance.

EN

2.2 Copyright Protection

This instruction manual, and texts, drawings and images included in it, as well as its other components are copyright protected. It is prohibited to reproduce this instruction manual (including its excerpts), in any form and by any means, and to use and/or transfer its content to third parties without manufacturer's written permission. Violation of the above results in obligation to pay compensation. We reserve the right to claim further damages.

2.3 Declaration of Conformity

The appliance meets the currently applicable standards and guidelines of the European Union. We confirm the above in the EC Declaration of Conformity. We may provide relevant Declaration of Conformity upon request.

3 Transport, Packaging and Storage

3.1 Delivery Check

Immediately upon reception, check the delivery for completeness and possible shipping damage. In the case of visible transport damage refuse to accept the appliance or accept it conditionally. Mark and note the scope of damage in shipping documents/consignment list of the shipping company and lodge a complaint. Concealed damage must be reported immediately upon its discovery, as compensation claims may only be filed within applicable time limits.

If you find that parts or accessories missing, please contact our Customer Service Department.

3.2 Packaging

Do not dispose of the appliance cardboard box. It may be used to store the appliance when relocating or when shipping the appliance to our service point in the case of any damages.

The packaging and its elements are made of recyclable materials. Particularly, these are: plastic films and bags, cardboard box.

When disposing of the packaging, observe applicable domestic regulations. Recyclable packaging materials should be recycled.

EN

3.3 Storage

Leave the packaging closed until installation of the appliance; observe external indications concerning method of placing and storage. Store the packaging in the following conditions only:

- in closed rooms;
- in dry and dust-free surrounding;
- away from aggressive agents;
- in a location protected against sunlight;
- in a location protected against mechanical shocks.

In the case of extended storage (over three months), make sure you check the condition of the packaging and the parts regularly. If needed, replace the packaging with a new one.

4 Technical Data

4.1 List of Components of the Appliance

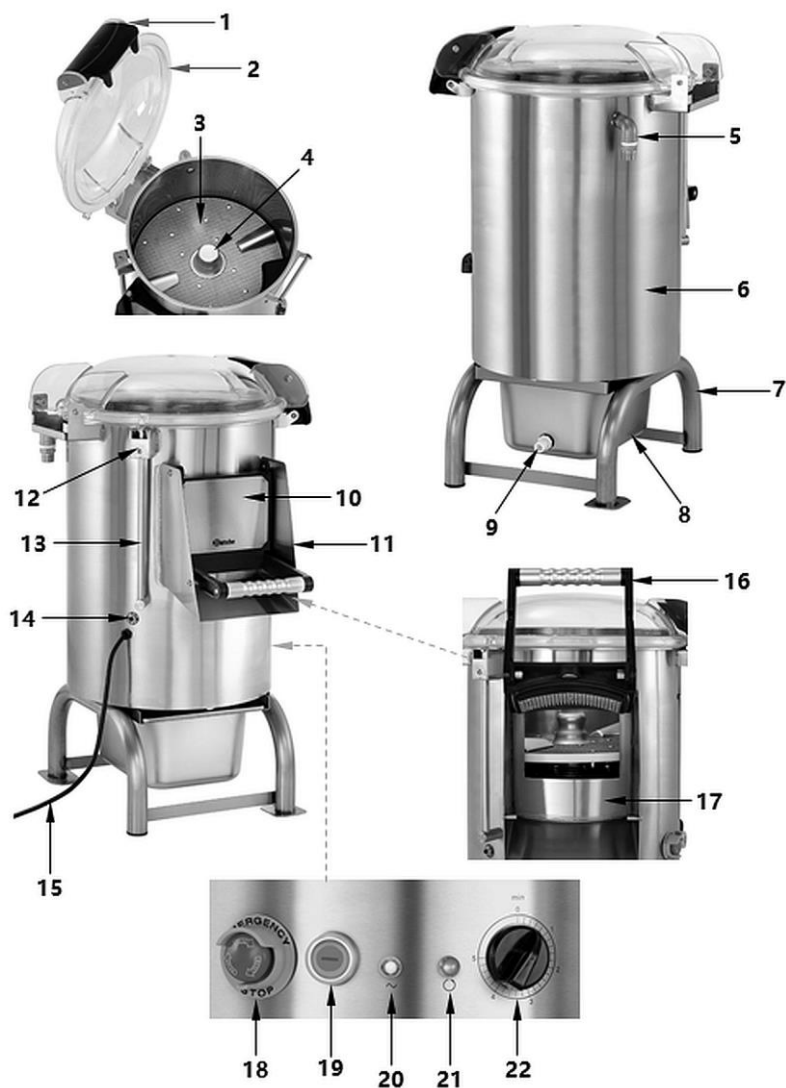

EN

Fig. 1

Description for Fig. 1

- | | |
|---------------------------------------|------------------------------------|
| 1. Lid lock | 2. Top lid |
| 3. Grater disk, removable | 4. Motor fixture |
| 5. Water connection | 6. Housing |
| 7. Base | 8. Collection container with sieve |
| 9. Water drain | 10. Feeder chute flap |
| 11. Feeder chute | 12. Lid micro-switch |
| 13. Cord tube | 14. Safety switch |
| 15. Power cord | 16. Feeder flap handle |
| 17. Feeder chute | 18. Emergency switch |
| 19. Pulse operation key | 20. ON/OFF indicator light (white) |
| 21. Operation indicator light (green) | 22. Timer |

Control Elements Functions

18 Emergency switch

Pressing the emergency switch results in instantaneous stop of the appliance. All other keys/switches are deactivated until the emergency switch is reset by rotating it clockwise.

19 Pulse operation key

This key is used for ejecting potatoes when the peeling process is off and the appliance stops.

ATTENTION!

Do not press the pulse operation key during the peeling process.

20 ON/OFF indicator light (white)

This indicator light is lit when the appliance is connected to the mains electric supply.

21 Operation indicator light (green)

This indicator light is lit when the peeling process is started through setting the operation time with the use of the timer.

22 Timer

The timer is used for setting the required operation time (0–5 minutes) and starting the peeling process.

4.2 Technical Specifications

Name:	Potato peeling machine 10KG
Art. No.:	120198
Material:	stainless steel
Capacity, in kg:	10
Max. output, in kg / hour:	130
Maximum rotational speed, in RPMs:	1200
Speed control, levels:	1
Time setting, from–to, in min.:	0 - 5
Water connection:	3/4"
Degree of protection:	IP23
Connected load:	0,75 kW 230 V 50 Hz
Dimensions (W x D x H), in mm:	670 x 540 x 860
Weight, in kg:	37,8

EN

We reserve the right to implement technical modifications.

Version / Characteristics

- Timer
- Overload protection
- Emergency switch
- Indicator lights:
 - ready for operation
 - appliance in operation

Protective Devices

Microswitch: The microswitch is equipped with a magnetic mechanism. The appliance switches off automatically, when the top lid or front flap are not closed or are opened during operation.

Emergency switch: In an emergency situation (e.g., on the event of clogging, strange vibrations or sounds, etc.), immediately operate the emergency switch. The appliance stops. All keys/switches are deactivated into the emergency switch is reset.

NOTE!

To reset the emergency switch, rotate it clockwise to its initial position.

Circuit breaker: This switch is used for protecting the circuit against damage resulting in overtension caused by overloading or short-circuit. When the error is detected, this switch interrupts flow of electric current.

NOTE!

To reset this switch, press it when you have already remedied the problem.

4.3 Functions of the Appliance

The appliance operates as a grater. To this end, a round grater disk is installed in the cylindrical housing, which is connected to the motor. During operation, potatoes are set in a circular motion, thus they are peeled.

Using the grater disk you may set in motion 130 kg of potatoes per hour. Functions, such as the timer and emergency switch, provide for smooth and safe operation.

5 Installation and operation

5.1 Installation



CAUTION!

Incorrect installation, positioning, operation, maintenance or misuse of the appliance may lead to personal injury or property damage.

Positioning and installation, as well as repairs may be performed by authorised technical service only and in compliance with the applicable national law.

NOTE!

The manufacturer disclaims all liability and provides no warranty for damages, which may be attributed to non-observance of regulations or incorrect installation.

EN

Unpacking / Positioning

- Unpack the appliance, remove all external and internal packaging elements and shipment safeguards.



CAUTION!

Choking hazard!

Prevent children from accessing package materials, for instance: plastic bags and EPS.

- If the appliance is covered with a protective film, remove it. Remove the film slowly, so no glue residues are left. Remove any glue residues with the use of a suitable solvent.
- Be careful not to damage the rating plate and warning labels fixed on the appliance.
- **Never** place the appliance in humid or wet environment.
- Place the appliance in a way making the connections easily accessible, so that they may be quickly disconnected if such a need arises.
- The appliance should be placed on surfaces that are:
 - even, with sufficient bearing capacity, resistant to water, dry and resistant to high temperatures;

Installation and operation

- sufficiently large, and thus enabling usage of the appliance with no problems;
 - easily accessible;
 - well ventilated.
- The appliance is delivered packed in a card-box on a plywood pallet, thus providing for full transport safety.
- Remove the card-box following the instructions.
- Open the card-box and make sure that all parts are intact.
- Lift the appliance according to the instructions and set it down in the designated installation location.
- Maintain sufficient clearance from table edges. The appliance might turn over and fall down.

Power supply connection

- Verify if technical data of the appliance (see rating plate) correspond with the local electric power grid specification.
- Connect the appliance to a single, properly grounded mains socket with protective contact. Do not connect the appliance to a multi-socket.
- The power cord should be laid in a way preventing anyone from threading on it or tripping against it.

- Check if the grounding system operates correctly.
- The appliance is equipped with a power cord with plug. Connect the appliance to a single grounded wall socket with a disconnecter.

Connection to Water Supply and Sewage System

1. Connect the appliance to water supply with the supplied hose (1.5 m) and 3/4" connectors. Proceed the following way:
 - connect the hose to the water supply at the back of the appliance;
 - connect the other end of the hose to the water supply.

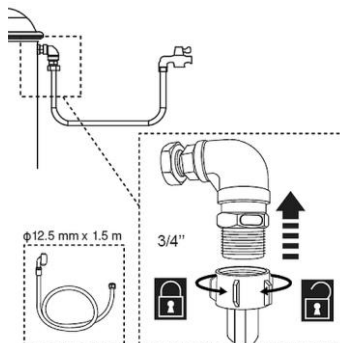

Fig. 2

EN

2. Use the clamp band to fix the suitable drain hose to the collection container drain.
3. Introduce the other end of the hose to the drain system.

The drain hose and clamp bands are not part of the delivery.

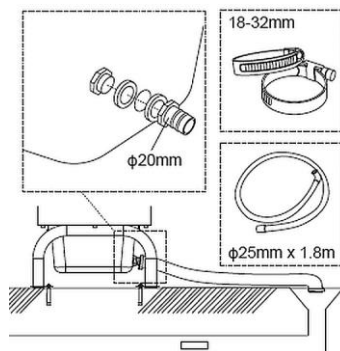

Fig. 3

5.2 Operation

Before First Use

1. Before the first use it is required to clean the appliance thoroughly with the use of warm water, soft cloth or sponge, and gentle detergent. Follow the instructions in section **6 'Cleaning'**.
2. Wipe the cleaned elements and surfaces with a cloth soaked in fresh water and then dry them thoroughly.

Appliance Operation



EN

Fig. 4

1. Open the transparent lid by pulling it upwards with the handle (1).
2. Install the grater disk.
3. Fill the container (peeling chamber) with potatoes.
4. Close the lid.
5. make sure the feeder chute flap (10) is locked.
6. Place a suitable container (e.g., a bucket, pot) under the chute.
7. Open the shut-off valve of the water supply system.
8. Plug the appliance into a suitable single socket.
The white ON/OFF indicator light lights up. (20).
9. Start the peeling process by setting the timer (22) to the required time in the range of 0–5 minutes.

The green operation indicator light (21) will be lit.

When the time elapses, the appliance stops automatically.

The green operation indicator light goes off.

10. Open the feeder chute flap (10) using the handle (16) to this purpose.

11. Then press the pulse operation key (19), so that the peeled potatoes are ejected through the feeder chute (10) to the container underneath.

12. During this process keep the feeder chute flap (10) open and check if the peeled potatoes are ejected; do not touch it.

WARNING!

Injury hazard posed by the sharp grater disk.

Never introduce hands into the feeder chute to help ejecting potatoes.

Should an accident occur, press the emergency switch immediately.

ATTENTION!

When clogged, the grater disk and discharge pipe may negatively influence the appliance operation.

After each cycle, check the grater disk and discharge pipe for clogging, and clean them if needed.

EN

Collection Container with Sieve

The appliance is equipped with the collection container with sieve. Before operating the appliance, always install it under the appliance. Peeling residues are collected in this container, as well as water used during peeling process.

NOTE!

Empty the collection container with sieve regularly.

6 Cleaning and Maintenance

6.1 Safety Instructions for Cleaning

- Before cleaning, disconnect the appliance from the power supply.
- Leave the appliance to cool down completely.
- Make sure water does not enter the appliance. Do not immerse the appliance in water or other liquids during cleaning. Do not clean the appliance with a pressurized water jet.
- Do not use any sharp or pointed, nor metal implements (knife, fork, etc.). Sharp or pointed implements may damage the appliance, and when in contact with live parts, they may cause electric shock.
- For cleaning, do not use any scouring agents that contain solvents nor corrosive cleaning agents. They may damage the surface.

6.2 Cleaning

WARNING!

Injury hazard posed by the sharp top surface of the grater disk.

When removing and cleaning the grater disk, exercise utmost caution. Wear safety gloves, resistant to cutting.

NOTE!

The grater disk is not suitable for washing in a dishwasher.

1. At the end of a working day, clean the appliance thoroughly.
2. Open the top lid and remove the grater disk from the peeling chamber.
3. Clean the grater disk and the inside of the peeling chamber using warm water and a suitable plastic dish-washing brush.
4. To end with, rinse with fresh water.
5. Leave the cleaned elements to dry in open air.
6. Clean the top lid (including the gasket), the outside of the appliance and feeder chute thoroughly with a soft, damp cloth. Use a mild cleaning agent if required.
7. Wipe with a clean cloth.
8. Finally dry all cleaned parts and surfaces with soft cloth.
9. Empty the collection container with sieve and clean it with warm water, using a cloth or a sponge. Dry the container with a soft, dry cloth.

ATTENTION!

The appliance may be stored and operated only when it has dried sufficiently after cleaning.

6.3 Maintenance

- Let the appliance to be inspected by professional technician at least once a year or as required.

7 Disposal

Electrical Appliance



Electric appliances are marked with this symbol. Electrical appliances must be disposed of and recycled in a correct and environmentally friendly manner. You must not dispose of electric appliances with household waste. Disconnect the appliance from the power supply and remove power cord from the appliance.

EN

Electrical appliances should be returned to designated collection points.