

„M+E“ 370



116019

ENGLISH

Table of contents

1. Safety 18
1.1 Key to symbols 18
1.2 Safety instructions 19
1.3 Proper use 22

2. General information 23
2.1 Liability and Warrantees 23
2.2 Copyright protection 23
2.3 Declaration of conformity 23

3. Transport, packaging and storage..... 24
3.1 Delivery check 24
3.2 Packaging..... 24
3.3 Storage..... 24

4. Technical data 25
4.1 Technical specification 25
4.2 Overview of parts 26

5. Installation and operation..... 27
5.1 Installation 27
5.2 Operation..... 30

6. Cleaning and maintenance 31

7. Waste disposal 32

Bartscher GmbH
Franz-Kleine-Str. 28
33154 Salzkotten
Germany

phone: +49 5258 971-0
fax: +49 5258 971-120
Service-Hotline: +49 5258 971-197
www.bartscher.com



Read this instruction manual before using and keep them available at all times!

This instruction manual contains information about the installation, operation and maintenance of the device and should be consulted as an important source of information and reference guide.

Awareness of the safety instructions and instructions for use in this manual will ensure the safe and correct use of the device.

In addition to the information given here, you should comply with any local Health and safety Controls and generally applicable safety regulations.

The instruction manual forms part of the product and should be kept near the device and easily accessible for anyone carrying out the installation, servicing, maintenance or cleaning.

Please keep these instructions and give them to future owners of the device.

1. Safety

This device is designed in accordance with the presently applicable technological standards. However, the device can pose a danger if handled improperly and inappropriately.

All persons using the device must follow the recommendations and instructions in this instruction manual.

1.1 Key to symbols

In this manual, symbols are used to highlight important safety instructions and any advice relating to the device. The instructions should be followed very carefully to avoid any risk of accident, personal injury or material damage.



DANGER!

This symbol highlights hazards which could lead to injury.



WARNING!

This symbol highlights dangerous situations which could lead to injury or death.



HOT SURFACE!

This symbol is a warning that the device surface is hot when in use. Ignoring this warning may result in burns!



CAUTION!

This symbol highlights dangerous situations which could lead to light injuries, or damage, malfunction, and/or destruction of the device.



NOTE!

This symbol highlights recommendations and information aimed for effective and trouble-free device operation.

1.2 Safety instructions

- The device is not intended for use by individuals (including children) with physical or mental disabilities, insufficient experience, and/or insufficient knowledge unless such persons are under the care of a person responsible for their safety or have received instructions regarding appropriate use of the device.
- Take care of children to keep them playing with or starting the device.
- **Never** leave the device unattended when in use.
- Only use the device indoors.
- The device must be operated in correct and safe technical condition only. In case of operational problems disconnect the device from the power supply (pull the plug from the socket) and contact the service company.

- Prevent access of children to the package materials like plastic bags and foamed polystyrene elements. **Suffocation hazard!**
- Only a qualified technician and using original spare parts and accessories should carry out repairs and maintenance of the device. **Do not attempt to repair the device yourself.**
- Do not use any accessory or spare parts that have not been recommended by the manufacturer. These can be dangerous for the user or lead to damages of the device or personal injury, and further, the warranty expires.
- To prevent hazards and to ensure optimum efficiency, no modifications or alterations to the device that are not explicitly approved by the manufacturer may be undertaken.



DANGER! Electric shock hazard!

To avoid the hazard results please follow the safety instructions below.

- Never allow the power cable to come into contact with heat sources or sharp edges. The power cable should not hang over the side of the working surface. Ensure that no one can step on or trip over the cable.
- The power cable must not be folded, bent or tangled, and must always remain fully unrolled. Never place the device or other objects on the power cable.
- Do not cover the cable. Keep away the cable from operating range and do not immerse it into water.

- Check the power cord regularly for damage. Do not use the appliance if the power cord is damaged. If this cable is damaged, it must be replaced by customer service or a qualified electrician in order to avoid dangers.
- Never carry or lift the device by the supply cable.
- In any case do not open the device housing. In case of electrical or mechanical modifications the **electric shock hazard** will occur.
- Do not use any acid agents and make sure no water ingresses the device.
- **Never** operate the device with moist hands or standing on wet floor.
- Disconnect the device from the electric power supply.
 - when the device is not used,
 - in case of anomalies during operation,
 - before cleaning.



HOT SURFACE! Risk of burns!

Follow the safety instructions listed in order to avoid the hazard:

- Hot steam from the combi-steamer may cause burns of face, hands, and arms. Carefully open the door of the combi-steamer.
- The condensation hood is still hot after work. The device should be cold before cleaning.

1.3 Proper use



CAUTION!

The device has been designed and built for commercial use and should be operated only by qualified personnel in kitchen facilities.

The operational safety of the device is assured only in case of proper use, according to the operation manual.

All technical activities like installation and maintenance must be performed by the qualified service personnel only.

The task of the condensation hood is condensation of steam and vapours from the combi-steamers.



CAUTION!

Any use going beyond the intended purpose and/or any different use of the device is forbidden and is not considered as conventional.

Any claims against the manufacturer or his authorized representative as a consequence of experiencing damages resulting from unconventional use are impossible.

The operator is liable for all damages resulting from inappropriate use.

2. General information

2.1 Liability and Warrantees

All the information and instructions in this manual take into account standard safety regulations, current levels of technical engineering as well as the expertise and experience we have developed over the years.

The instruction manual was translated with all due care and attention. However, we do not accept liability for any translation errors. The German version of this instruction manual is definitive.

If the delivery consists of a special model, the actual scope of delivery may differ from the descriptions and illustrations in this manual. This is also the case for special orders or when the device has been modified in line with new technology.



CAUTION!

Read this manual carefully and thoroughly before any operation of the device, and especially before turning it on!

Manufacturer **is not liable** for any damages or faults caused by:

- violation of advice concerning operation and cleaning;
- use other than designed;
- alterations made by user;
- use of inadequate spare parts.

We reserve the right to make technical changes for purposes of developing and improving the useful properties.

2.2 Copyright protection

The instruction manual including any texts, drawings, images or other illustrations is copyright. No part of this publication may be reproduced, transmitted or used in any form or by any means without permission in writing from the manufacturer. Any person who commits any unauthorized act in relation to this publication shall be liable to claims for damages. All rights reserved.



NOTE!

The contents, texts, drawings, pictures and any other illustrations are copyright and subject to other protection rights. Any person unlawfully using this publication is liable to criminal prosecution.

2.3 Declaration of conformity



The device complies with the current standards and directives of the EU. We certify this in the EC declaration of conformity. If required we will be glad to send you the according declaration of conformity.

3. Transport, packaging and storage

3.1 Delivery check

Please check the delivery upon completeness and transport damage immediately after receipt. In case of visible damage do not accept or accept the delivery with reservation only.

Note the extent of damage on the carrier's bill of delivery. Trigger off the complaint.

Hidden damages should be reclaimed immediately after notice, as claims for damages can only be asserted within the effective period for complaints.

3.2 Packaging

Please do not throw away the covering carton of your device as it might be useful for storage purposes, when moving or, in case of damages, when the device must be sent back to a repair center. The outer and inner packing material should be removed completely from the device before installation.



If you liked to dispose the packing, consider the regulations applicable in your country. Supply re-usable packing materials to the recycling.

Please inspect the device upon completeness. In case any part is missing please contact our customer service center immediately.

3.3 Storage

Keep the package closed until installation and under consideration of the outside indicated positioning- and storage markings.

Packages should be stored under consideration of the following:

- do not store outdoors,
- keep it dry and dust-free,
- do not expose it to aggressive media,
- do not expose it to direct sunlight,
- avoid mechanical shocks and vibration,
- in case of longer storage (> 3 months) make sure you check the state of the packaging and the parts regularly, if required refresh or renew.

4. Technical data

4.1 Technical specification

Description	Condensation hood "M+E" 370
Code-No.:	116019
Material:	Stainless steel
Realization:	<ul style="list-style-type: none"> ▪ Designed for Bartscher combi-steamers GN 1/1 Series M and E**, except series E RS ▪ Filter: <ul style="list-style-type: none"> - Labyrinth filter - Material: stainless steel - Number 2 ▪ Number of fan motors/exhaust air outputs: 1 ▪ Fan regulation: <ul style="list-style-type: none"> - Manual - Stepless - Toggle ▪ ON/OFF switch
Motor output:	800 m ³ - 1500 m ³
Power:	0.37 kW / 230 V 50/60 Hz
Dimensions:	W 870 x D 950 x H 300 mm
Connection cable:	2.3 m
Weight:	31.2 kg
Includes:	Connection material (spiral pipe): Attachment material (2 x backing plate, 4 x mounting screw)

We reserve the right to make technical changes!

**** This condensation hood must be used only for the following combi-steamers:**

M5110 / 116116

M7110 / 116618

M10110 / 116621

E5110 / 116526

E7110 / 116528

E10110 / 116531

4.2 Overview of parts

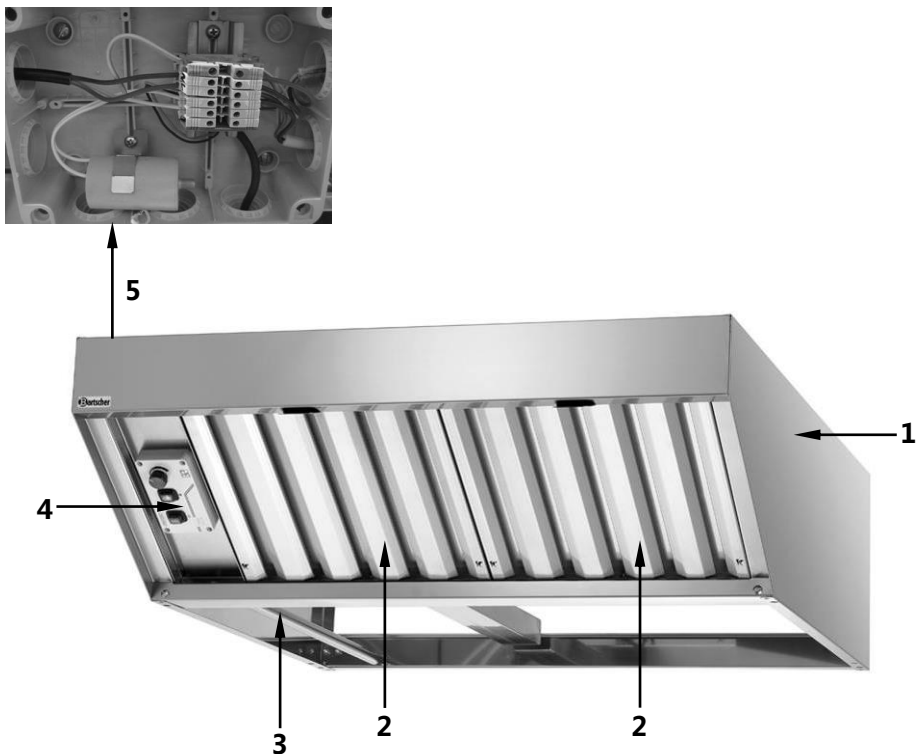

- 1 Housing
- 2 Filter (2)
- 3 Dripping trough for condensed water
- 4 Operation elements
- 5 Distribution box for power supply connection

Operating elements

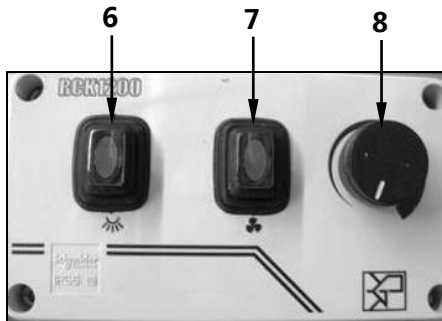

- 6 Lighting button (inactive)
- 7 ON/OFF switch
- 8 Motor speed control toggle

5. Installation and operation

5.1 Installation



CAUTION!

Any installation, connection and maintenance work related to the device must be performed by the qualified and certified technician in accordance with the applicable international, national and local regulations.

- Unpack the condensation hood and remove all packaging material according to the regulations valid in the country of installation.
- The device must be used in properly ventilated room in order to avoid excessive condensation of harmful substances in the air.
- The condensation hood does not require connection to the ventilation system, steam and vapours are condensed by the labyrinth filter and removed by the dripping trough.
- Make sure that no flammable substances are stored or used in the vicinity of the device.
- The device must not be started in the toxic or explosive environment.

Installation of the condensation hood

- Put the condensation hood on the upper cover of the combi-steamer (section 4.1 “**Technical specification**”) and assure good adherence. Make sure that the supply cable is not blocked between the devices.
- Remove the protective foil from the device before use. Remove the foil slowly in order to not to leave the glue residuals. Any glue residuals may be removed with use of proper solvent.



CAUTION!

Never remove the rating plate or any warning signs from the appliance.

- Attach the condensation hood on the back wall of the combi-steamer with use of the supplied plates and mounting screws.



Connecting to the extraction connection

- The spiral pipe is located on the back wall of the condensation hood and should be inserted to the extraction connection of the combi-steamer.

Steam is collected and removed during the operation of the condensation hood.



Spiral pipe

Vapours outlet
Combi-steamer

Connecting to the drain

- Connect the drain hose (not included) to the dripping trough. Hose should have internal diameter of 20 mm. Fix the hose with use of clamping band.



Dripping trough
for condensed
water

Connection



DANGER! Electric shock hazard!

The device can cause injuries due to improper installation! Before installation and connecting the local power grid specification should be compared with that of the device (see rating plate). Connect the device only in case of compliance!

- The power supply circuit with the socket must be protected by the fuse of at least 16A. Connect the device directly to a single grounded socket. Do not use any power bar or multiple socket.

5.2 Operation

Operation principle

The first steam released through the combi-steamer door passes through the labyrinth filter located on the front wall of the condensation hood.

The operation principle consists in metal (aluminium) condenser through which the sucked steam is passed.

Temperature difference between steam (hot) and aluminium surface (cold) causes steam condensation and collection by the internal trough under the condenser, which is then removed through the hose connected to the drain.

Then on the back wall of the condensation hood there is the spiral pipe connected to the combi-steamer extraction connection. That pipe is always in the state of slight negative pressure (during the hood operation) and collects vapours from the combi-steamer.

Prepare the device

- The device should be thoroughly cleaned before the first use. Follow instructions in **section 6 “Cleaning and maintenance”**.

Device start-up

- Connect the device to a single grounded socket.
- When it is required, switch the condensation hood with the ON/OFF switch.
- The motor speed is controlled steplessly with use of a motor speed control toggle. Rotate the controller clockwise to increase speed or anti-clockwise to reduce it.
- When the device is not to be used anymore it should be turned off with use of the ON/OFF switch.

6. Cleaning and maintenance



WARNING

Before cleaning the device, disconnect it from the power supply.

Never wash the device with use of direct water jet or pressure washer!

Make sure that no water gets into the device.

Cleaning of the device

- Clean the condensation hood periodically.
- Clean it with a soft cloth only and **never** use any abrasive cleaning agents that could cause damage to the surfaces of the device.
- Do not use any wire brushes or metal scrappers.
- **Housing** of the device should be periodically wiped with soft cloth moistened with warm water and gentle cleaning agent.
- All cleaned surfaces should be dried thoroughly.

Labyrinth filter cleaning

- The labyrinth filter should be cleaned periodically.
- Remove the labyrinth filters (fig. below) and wash it manually or in the dishwasher.

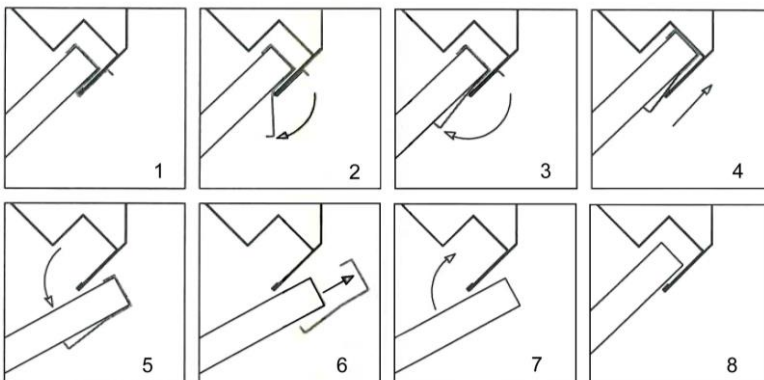

- Remove the control unit and clean its surface with a soft moist cloth.
- Thoroughly clean the internal side of the condensation hood.
- Dry the cleaned surfaces and reinstall the labyrinth filter and the control unit.

Maintenance

- We recommend to order the maintenance of the device in the professional service company at least once a year. Works interfering in the device must be realized by the professional and qualified personnel.

7. Waste disposal

Old devices



The electric devices are marked with this symbol. You must not dispose of electric devices with household waste. When the device may not be longer used each consumer is obliged to dispose of the device at the dedicated local collection point, separately from household waste.



NOTE!

Electric devices should be used and disposed of properly to prevent the impact on the environment.

- Disconnect the device from the power supply and remove the power cord from the device.

Bartscher GmbH
Franz-Kleine-Str. 28
33154 Salzkotten
Germany

phone: +49 5258 971-0
fax: +49 5258 971-120
Service-Hotline: +49 5258 971-197
www.bartscher.com