

RK501 LPWR



110645

Bartscher GmbH
Franz-Kleine-Str. 28
D-33154 Salzkotten
Germany

Phone: +49 5258 971-0
Fax: +49 5258 971-120
Technical Support Hotline: +49 5258 971-197
www.bartscher.com



Version: 2.0

Date of preparation: 2023-03-17

Original operation manual

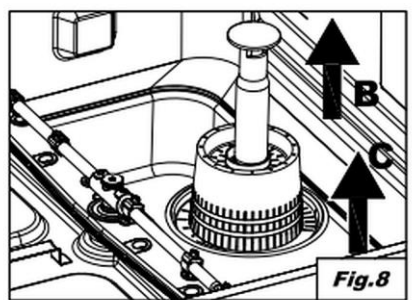
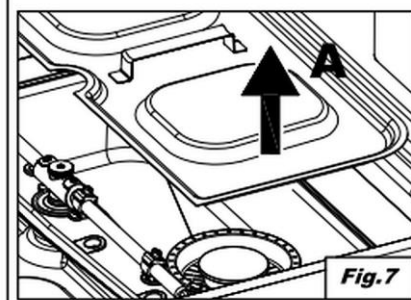
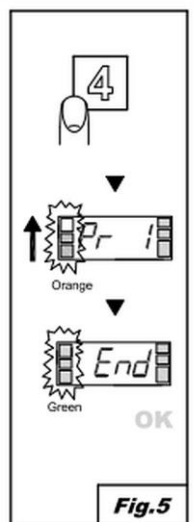
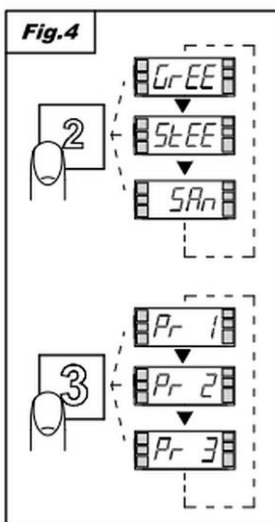
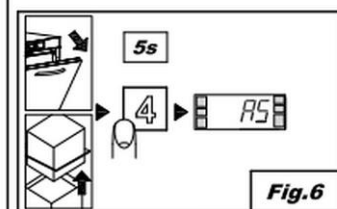
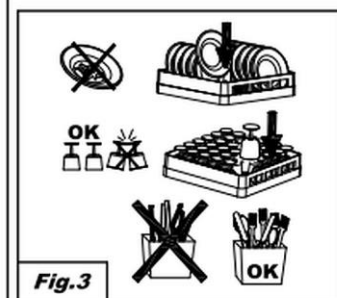
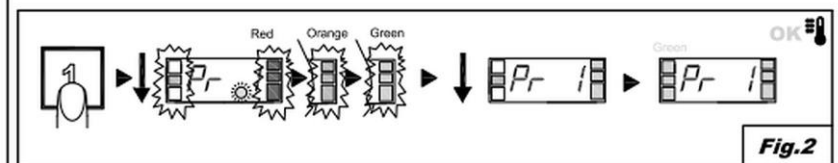
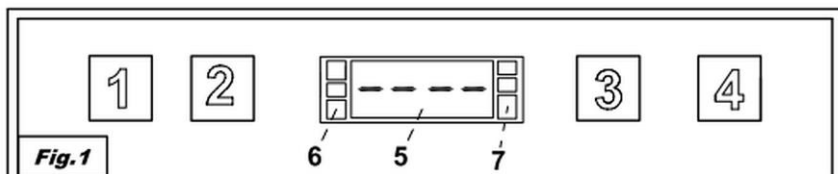

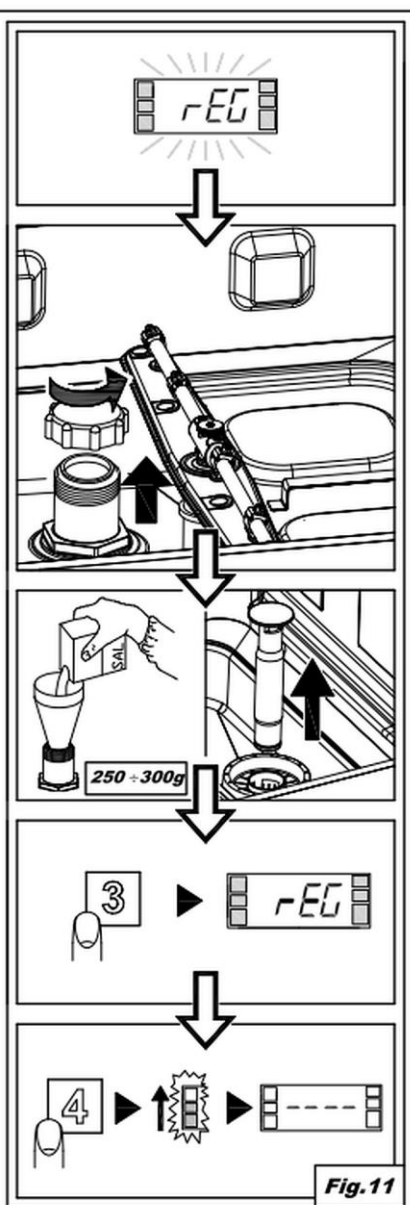
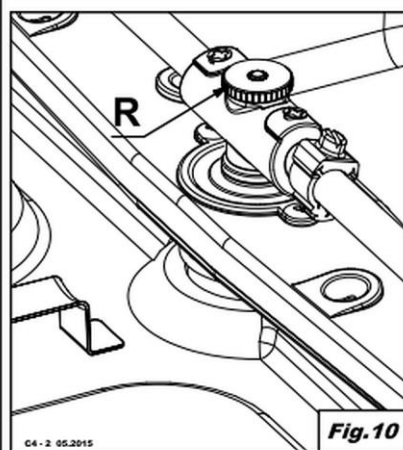
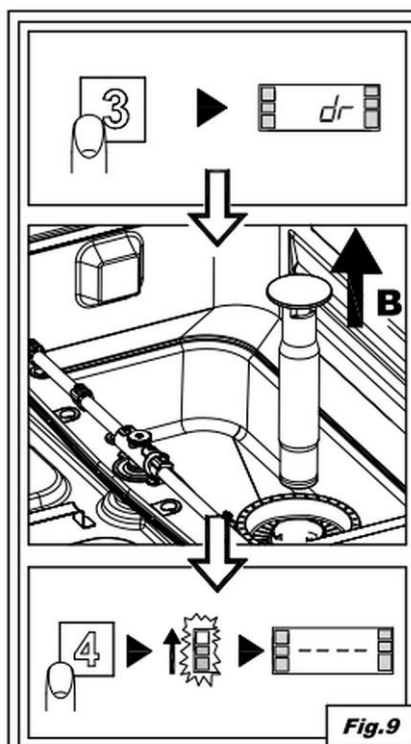

1	Safety	2
1.1	Explanation of Signal Words	2
1.2	Safety instructions.....	3
1.3	Intended Use	5
1.4	Unintended Use	5
2	General information	6
2.1	Liability and Warranty	6
2.2	Copyright Protection	6
2.3	Declaration of Conformity	6
3	Transport, Packaging and Storage	7
3.1	Delivery Check.....	7
3.2	Packaging	7
3.3	Storage	7
4	Technical Data.....	8
4.1	Technical Specifications	8
4.2	Functions of the Appliance.....	9
4.3	List of Components of the Appliance	10
5	Installation Instructions	11
5.1	Unpacking.....	11
5.2	Positioning	12
5.3	Electrical Connection	13
5.4	Water Connection	15
5.5	Drain Connection	16
5.6	Rinsing Agent Dosing Pump and Cleaning Agent Dosing Pump	17
6	Operation and Maintenance Instructions	19
6.1	Operation	19
6.2	Cleaning and Maintenance	26
6.3	Indications and Tips	28
7	Possible Malfunctions	30
8	Disposal.....	32



Read this instruction manual before using and keep it available at all times!

This instruction manual contains information about installation, operation and maintenance of the appliance and constitutes an important source of information and reference guide. The knowledge of all operational and safety instructions included in this manual is a prerequisite for safe and proper handling of the appliance. Additionally, accident prevention, occupational health and safety, and legal regulations in force in the area the appliance is used apply.

Before you start using the appliance, especially before turning it on, read this instruction manual in order to avoid personal injuries and property damages. Improper use may cause damage.

This instruction manual forms an integral part of the product and must be stored in an immediate vicinity of the appliance and be available at all times. The instruction manual should be transferred together with the appliance.

1 Safety

This appliance has been manufactured in accordance with technical standards currently in force. However, the appliance may be a source of hazards if used improperly or contrary to its intended purpose. All persons using the appliance must consider information included in this instruction manual and observe safety instructions.

1.1 Explanation of Signal Words

Important safety instructions and warning information are indicated in this instruction manual with appropriate signal words. You must strictly follow the instructions, to prevent accidents, personal injuries and property damages.



DANGER!

The signal word **DANGER** warns against hazards that lead to severe injuries or death if the hazards are not avoided.



WARNING!

The signal word **WARNING** warns against hazards that may lead to moderate or severe injuries or death if the hazards are not avoided.



CAUTION!

The signal word **CAUTION** warns against hazards that may lead to light or moderate injuries if the hazards are not avoided.

IMPORTANT!

The signal word **IMPORTANT** indicates possible property damages, which may occur if safety instructions are not observed.

NOTE!

The symbol **NOTE** indicates subsequent information and guidelines for the user on usage of the appliance.

1.2 Safety instructions

Electrical Current

- Too high a mains voltage or incorrect installation may cause electric shock.
- The appliance may be connected only if data on the rating plate correspond with the mains voltage.
- To avoid short-circuit, the appliance should be kept dry.
- If there are malfunctions during operation, disconnect the appliance from the power supply.
- Do not touch the appliance's plug with wet hands.
- Never take hold of the appliance if it has fallen into water. Immediately disconnect the appliance from the power supply.
- Any repairs or housing opening may be carried out by professionals and relevant workshops only.
- Do not transport the appliance, holding it by the power cord.
- Do not allow the power cord to come into contact with heat sources or sharp edges.
- Do not bend, pinch nor knot the power cord.

- Always completely unwind the power cord.
- Never place the appliance or other objects on the power cord.
- Always take hold of the plug to disconnect the appliance from the power supply.
- Check the power cord regularly for damage. Do not use the appliance if the power cord is damaged. If this cable is damaged, it must be replaced by customer service or a qualified electrician in order to avoid dangers.

Operating Personnel

- The appliance may only be operated by a qualified personnel and trained specialist personnel.

Improper Use

- Unintended or prohibited use may cause damage to the appliance.
- The appliance may only be used when its technical condition is flawless and allows for safe operation.
- The appliance may only be used when all connections are executed according to rules of law in force.
- The appliance may only be used when it is clean.
- Use only original spare parts. Never attempt to repair the appliance on your own.
- Do not introduce any changes in the appliance nor modify it.

1.3 Intended Use

As described below, every use of the appliance for a purpose differing and/or diverging from its intended standard use, is prohibited and considered to be an unintended use.

The following is an intended use:

- Washing dishes, glasses, pots, pans, etc.

The appliance is intended for professional use only.

1.4 Unintended Use

An unintended use may lead to personal injuries or property damages caused by hazardous voltage, fire or high temperature. The appliance may only be used to perform tasks described in this instruction manual.

The following is an unintended use:

- Washing other unsuitable objects.

2 General information

2.1 Liability and Warranty

All information and instructions in this instruction manual account for legal regulations in force, current level of technical engineering knowledge as well as our expertise and experience, developed over the years. If special models or additional options are ordered, or state-of-the-art technical solutions were implemented, the actual scope of delivery of the appliance may, in some circumstances, differ from descriptions and numerous drawings in this instruction manual.

The manufacturer is not liable for any damages nor faults stemming from:

- failure to observe instructions,
- unintended use,
- technical alterations introduced by the user,
- usage of unapproved spare parts.

We reserve the right to introduce technical modifications to the product, intended for improvement of the appliance and its performance.

2.2 Copyright Protection

This instruction manual, and texts, drawings and images included in it, as well as its other components are copyright protected. It is prohibited to reproduce this instruction manual (including its excerpts), in any form and by any means, and to use and/or transfer its content to third parties without manufacturer's written permission. Violation of the above results in obligation to pay compensation. We reserve the right to claim further damages.

2.3 Declaration of Conformity

The appliance meets the currently applicable standards and guidelines of the European Union. We confirm the above in the EC Declaration of Conformity. We may provide relevant Declaration of Conformity upon request.

3 Transport, Packaging and Storage

3.1 Delivery Check

Immediately upon reception, check the delivery for completeness and possible shipping damage. In the case of visible transport damage refuse to accept the appliance or accept it conditionally. Mark and note the scope of damage in shipping documents/consignment list of the shipping company and lodge a complaint.

Concealed damage must be reported immediately upon its discovery, as compensation claims may only be filed within applicable time limits.

If you find that parts or accessories missing, please contact our Customer Service Department.

3.2 Packaging

Do not dispose of the appliance cardboard box. It may be used to store the appliance when relocating or when shipping the appliance to our service point in the case of any damages.

The packaging and its elements are made of recyclable materials. Particularly, these are: plastic films and bags, cardboard box.

When disposing of the packaging, observe applicable domestic regulations. Recyclable packaging materials should be recycled.

EN

3.3 Storage

Leave the packaging closed until installation of the appliance; observe external indications concerning method of placing and storage. Store the packaging in the following conditions only:

- in closed rooms;
- in dry and dust-free surrounding;
- away from aggressive agents;
- in a location protected against sunlight;
- in a location protected against mechanical shocks.

In the case of extended storage (over three months), make sure you check the condition of the packaging and the parts regularly. If needed, replace the packaging with a new one.

4 Technical Data

4.1 Technical Specifications

Name:	Dishwasher RK501 LPWR
Art. No.:	110645
Material:	stainless steel
Basket dimensions (W x D x H), in mm:	500 x 500
Max. glass height, in mm:	260
Max. plate height, in mm:	270
Run time, in seconds:	60 / 90 / 180
Max. output / hour, baskets:	60
Number of wash programs:	3
Tank volume, in litres:	15
Water consumption, litres / wash cycle at 2 bars:	2,1
Water pressure, in bar:	2 - 4
Water supply:	G 3/4 " M
Water outlet, Ø in mm:	18
Tank heating, in kW:	1,4
Boiler heating, in kW:	6
Connected load:	7,9 kW 400 V 50 Hz
Dimensions (W x D x H), in mm:	600 x 710 x 825
Weight, in kg:	57,0

We reserve the right to implement technical modifications.

Version / Characteristics

- Equipment connection: 3 NAC
- Discharge pump
- Washing agent dosing pump
- Rinsing agent dosing pump
- Water softener
- Double-walled door
- Double-walled housing
- Cold rinse

Technical Data

- Automatic cleaning
- Door contact switch
- Dry-run protection
- Safety thermostat
- Can be fitted below the counter
- ON/OFF switch
- Indicator lights: ON/OFF, temperature
- Water intake temperature up to 50°C
- Cleaning set consisting of:
 - 1 washing agent tank
 - 1 rinsing agent tank
- Delivery condition: permanently mounted
- The set includes:
 - 1 universal basket
 - 1 glasses basket
 - 1 plate basket
 - 1 supply hose
 - 1 drain hose
 - 1 funnel for salt filling
- Properties: Surface strainer
- Display:
 - Boiler temperature
 - Fault messages
 - Programme code
 - Tank temperature
 - Maintenance display

4.2 Functions of the Appliance

The dishwasher that can be fitted below the counter is designed for washing glasses, cups, plates and cutlery. The appliance makes it possible to wash with an output of up to 60 baskets (500x500 mm) per hour, offering the selection of 3 wash programs. This dishwasher is a space-saving solution for small kitchens and sculleries. Thanks to the pre-installed cleaning kit with integrated tanks for detergent and rinsing agent, no further space for dishwasher accessories such as tanks and hoses is required in the kitchen.

4.3 List of Components of the Appliance

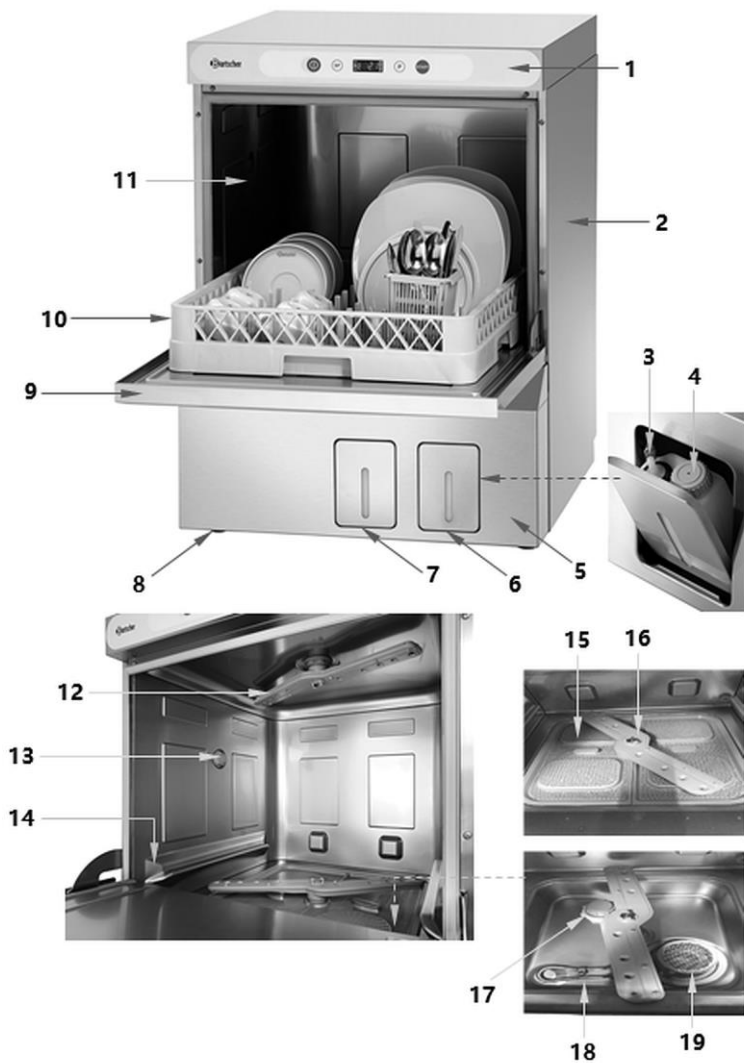

Fig. 12

Description for Fig. 12

- | | |
|-------------------------------------|---------------------------------------------------|
| 1. Control panel | 2. Housing |
| 3. Connection hose | 4. Canister with a washing agent or rinsing agent |
| 5. Cleaning set | 6. Rinsing agent tank flap |
| 7. Washing agent tank flap | 8. Feet (4 pcs) |
| 9. Appliance door with flush handle | 10. Wash basket (without tableware) |
| 11. Wash-tank | 12. Upper wash arm |
| 13. Reverse flow protection | 14. Wash basket guide rails (2 pcs) |
| 15. Bottom sieves (2 pcs) | 16. Lower wash arm |
| 17. Salt dispenser | 18. Chamber heater |
| 19. Drain hose | |

5 Installation Instructions



CAUTION!

Incorrect installation, positioning, operation, maintenance or misuse of the appliance may lead to personal injury or property damage.

Positioning and installation, as well as repairs or fitting may be performed by authorised technical service only and in compliance with the applicable national law.

NOTE!

The manufacturer disclaims all liability and provides no warranty for damages, which may be attributed to non-observance of regulations or incorrect installation.

5.1 Unpacking

- The appliance may be moved with the use of a fork lift or similar equipment only to avoid damaging the appliance's structure. First, deliver the appliance to the final installation location and unpack it there.
- Unpack the appliance, remove all external and internal packaging elements and shipment safeguards.



CAUTION!

Choking hazard!

Prevent children from accessing packaging materials, for instance: plastic bags and EPS.

- If the appliance is covered with a protective film, remove it. Remove the film slowly, so no glue residues are left. Remove any glue residues with the use of a suitable solvent.
- Be careful not to damage the rating plate and warning labels affixed to the appliance.

5.2 Positioning

ATTENTION!

Before installation check if there are no objects nor materials in the installation area that might get damaged by steam, which could get out of the appliance during operation or, alternatively, make sure that they are properly secured.

- **Never** place the appliance in humid or wet environment.
- Place the appliance in a way making the connections easily accessible, so that they may be quickly disconnected if such a need arises.
- The appliance should be placed on a surface that is:
 - even, with sufficient load-bearing capacity, resistant to water, dry and resistant to high temperatures;
 - sufficiently large, and thus enabling usage of the appliance with no problems;
 - easily accessible;
 - well ventilated.
- The appliance should be installed only in a room, in which ambient temperature falls in the range of 4–40°C.
- The relative humidity may not exceed the following values: max. 30% at 40°C / max. 90% at 20°C.
- Do not install the appliance in an immediate vicinity of heat sources exceeding 50°C.
- Never subject the appliance to adverse weather conditions (rain, sunshine, etc.).

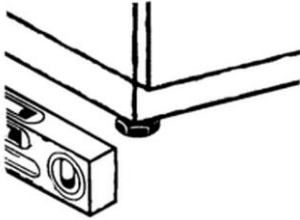

Fig. 13

- To provide for stability, level the appliance by screwing the feet in or out.
- Correct levelling is indispensable in ensuring optimum performance of the appliance.

5.3 Electrical Connection

- The power cord should be laid in a way preventing anyone from threading on it or tripping against it.
- In normal operation or maintenance, the power cord cannot be stretched out nor crushed.

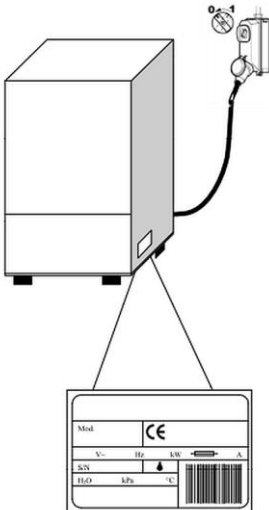

Fig. 14

- A universal main disconnector must be used that would disconnect all contacts, including the zero distributor. The disconnected contact must feature at least a 3 mm gap. The switch must be activated by a thermo-magnetic safety device or be coupled to fuses. The fuses and the switch must be designed for the power provided on the rating plate.
- The main switch must be located in the power line near the installation place. Only one appliance may be permanently connected to the main switch.
- Verify if the technical specification of the appliance (see the rating plate) corresponds to the characteristics of the local electric mains grid.

EN

- For the safety of the operator and the appliance, provide for proper grounding pursuant to the safety regulations in force.
- The appliance complies with the EN/IEC 61000-3-11 standard, on condition that the system impedance Z_{sys} is lower or equals Z_{max} at the interface between the

user's port and the public grid. The installer or the user of the appliance is responsible for providing that the appliance is connected to the mains supply with system impedance Z_{sys} is lower or equals Z_{max} .

	Z_{max}
Dishwasher	0,21 Ω
Pass-through dishwasher	0,24 Ω
Dishwasher for fitting	0,41 Ω

- Only connection cables, type H07RN-F, may be used; current-carrying capacity at continuous operation and 60°C at a cord:

Three-phase appliances

- - 5x2.5 mm² up to 20 A
- - 5x4 mm² up to 30 A
- - 5x6 mm² up to 38 A
- - 5x10 mm² up to 54 A

Single-phase appliances

- - 3x1.5 mm² up to 16 A
- - 3x2.5 mm² up to 25 A

- The appliance must be integrated with the potential safety equalization system. Connection is executed via the screw with 5021 symbol, pursuant to IEC 60417



Potential equalization cord cross-section must be 10 mm².

5.4 Water Connection

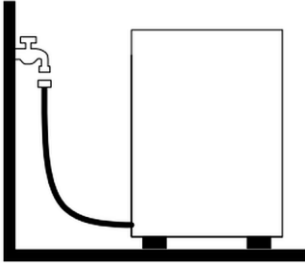

Fig. 15

- The appliance is connected with a hose to a water supply system.
- Between the water connection and the appliance's solenoid valve, a cut-off valve must be installed. The cut-off valve must be positioned in the vicinity of the appliance.
- The water supply system, temperature and pressure must comply with data on the appliance's rating plate.

- A water flow in the water supply system may not be lower than 20 litres/minute.
- With water hardness exceeding 14 °fH (8 °dH), it is recommended to use an appliance with a built-in water softener. With water hardness exceeding 35 °dH (19.5 °dH), it is recommended to install an external water softener before the solenoid valve.

High electric conduction of water indicates a very high concentration of minerals dissolved in water; in such a case, demineralization device should be installed.

- Appliances intended for operation with desalted water or water with high concentration of sodium chloride should be ordered separately, as special minerals are required for their construction.
- Appliances equipped with a heat recovery installation with copper tubing may not be operated with de-mineralized water. In such cases, a version with heat exchanger with stainless steel tubing should be ordered.
- Furthermore, when checking the water quality, the pressure of water supply system must be taken into account. This parameter determines the correct operation of the appliance.

The required water pressure is 2–4 bar.

Water pressure	MIN				MAX			
	bar	kPa	kg/cm ²	psi	bar	kPa	kg/cm ²	psi
	2	200	2,03	29	4	400	4,07	58,01

- If the water pressure exceeds the recommended value, it is required to install a pressure controller between the water supply system and the water connection of the appliance.
- If the water pressure is below the recommended value, it is required to install the booster pump at the water supply system connection.
- The appliance is intended to be connected to a permanent water mains connection. When using warm water, the water temperature may not exceed the values of 50°C/122°F.

5.5 Drain Connection

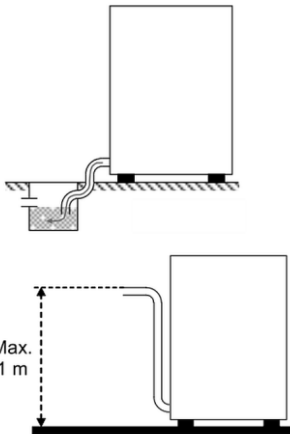

Fig. 16

- Water drain tube must consist of a sump with free drain trap. Dimensions must be suitable for the flow rate of the drain hose delivered with the appliance. The drain hose must be introduced into the sump without pulling, bending, clenching, kinking and any other obstacles.
- Emptying the sump is executed by means of gravitation, i.e. the drain must be located below the bottom of the appliance.
- If the drain is not below the bottom of the appliance (as in a model with drain pump), the maximum allowable drain height is 1 metre.
- Check regularly if the drain works correctly and for possible clogging.
- Any other solutions must be consulted with and approved of by the manufacturer beforehand.

ATTENTION!

Following installation, the installer must issue a written statement and confirm that the installation and commissioning test have been conducted correctly and professionally, pursuant to statutory provisions in force in the installation location.

5.6 Rinsing Agent Dosing Pump and Cleaning Agent Dosing Pump

The appliance is equipped with the **rinsing agent dosing pump**. Thanks to this dosing device, the appropriate quantity of rinsing agent is added to the wash-tank each time.

Located at the rear of the appliance, the hose with marking for rinsing agent should be introduced to the rinsing agent tank.

The hoses are transparent, thus the introduced chemical compounds are always visible.

Operation method: Thanks to this dosing device, the liquid rinsing agent is supplied whenever a drop in pressure is detected during rinsing. This happens when the filling valve is closed. As an outcome, underpressure is generated, which causes the liquid to be sucked by the rinsing agent dosing device.

Setting: this dosing device should be set up during the installation, because this is the only way the user may use all washing features in an optimum way from the very beginning. The setting must be properly adjusted depending on the selected rinsing agent and hardness of the available water.

NOTE:

A selection of the rinsing agent and setting of the rinsing agent dosing pump should be ordered with a qualified technician who has experience with chemical products, to achieve the most efficient washing effects.

The appliance is equipped with the washing agent dosing pump. Thanks to this dosing device the appropriate quantity of washing agent is added to the wash-tank each time.

Located at the rear of the appliance, the hose with marking for washing agent should be introduced to the washing agent tank.

Operation method: The washing agent dosing pump is activated when the appliance collects water during washing or filling process.

Setting: The quantity of washing agent should be set during the installation at the washing agent dosing pump, so that the user may use all washing features in an optimum way from the very beginning.

The hose in the washing agent dosing pump must be replaced annually.

ATTENTION!

Use ONLY liquid washing agent, designed for professional use, which is suitable for using in high temperatures and shows little foaming properties.

To achieve the most efficient washing effects, the selection of the washing agent and setting of the washing agent dosing pump should be ordered with a qualified technician, who has experience with chemical products.

Cleaning Set

The appliance is equipped with the cleaning set.

The cleaning set consists of:

- 1 washing agent tank
- 1 rinsing agent tank

The stainless steel element features two compartments: for a washing agent and rinsing agent. In each of the compartments, there is a small tank.

6 Operation and Maintenance Instructions

Indications for User

- **In no case** may the appliance door be opened during the wash cycle, even for a very short time.
- Never use the dishwasher without safety elements provided by the manufacturer.
- Never use the dishwasher to wash objects that are not dishwasher-safe, that cannot be washed in a dishwasher due to their shapes or dimensions or that are in poor condition.
- Never use the wash-tank nor the top section of the appliance as a shelf/storage location for any objects.
- Never overload open appliance door. The appliance door are designed to withstand the weight of the basket filled with tableware.
- In the event of a failure or spill, interrupt the power and water supply immediately.
- Never start the wash program without overflow (should it be activated).
- Never put bare hands in the washing solution.

EN

6.1 Operation

Preparation of the Appliance

1. Before first use, clean the appliance according to instructions in section 6 'Cleaning and Maintenance'.
2. Dry the appliance thoroughly.

Functions of Operating Elements / Indicators (Fig. 1 at the beginning of the instruction manual)

1	ON/OFF switch	5	Information in the display
2	Special program selection key	6	LED operation indicator
3	Program selection key	7	LED control indicator
4	START key		

Switching the Appliance On (Fig. 2)

Before switching the appliance on make sure that the following conditions are met:

- the main switch is off,
- water shut-off valve is open,
- water supply is ensured,
- overflow (if available) is in the right location,
- appliance door is closed.

NOTE!

To start the filling process, the appliance door must be fully closed. Due to safety reasons, the appliance cannot be filled with door open.

1. Press the ON/OFF switch (1).

The control indicator (7) lights up red first and then green, when the test is finished. In the event of a serious failure, the LED strip lights up red and the appliance operation is interrupted; in the case of a non-critical error, it lights up yellow, and the appliance operation is not interrupted.

The water supply starts automatically when the appliance is switched on.

The display indicator blinks until the filling level is reached.

When the appliance heats up, the operation control LED indicator lights (6) are lit from top to bottom.

When the operation temperature is reached, the operation indicator LED (6) lights up green with constant light.

Optimum conditions for dish-washing have been reached.

Tableware Preparation / Loading the Tableware Basket (Fig. 3)

If possible, tableware and cutlery should be washed immediately after use, so that food residues do not dry out and stick on them.

Use the dishwasher to wash non-breaking tableware only that is dishwasher-safe.

When filling the dishwasher baskets pay attention to the following:

max. glass height: 260 mm; max. plate height: 270 mm

1. Prepare tableware for washing: remove larger chunks of food left-overs before placing the tableware in baskets. Select baskets that are suitable for tableware that is to be washed.
2. Wash glasses first. Always place glasses face down. Use the basket that is suitable for glasses.
3. Plates and flat tableware with internal surface bent upwards should be placed in a basket in a diagonal position.
4. Place the cutlery in the cutlery holder with handles facing down. Cutlery of various sizes and types should be mixed.

NOTE!

Silver and stainless steel cutlery should not be placed in the same cutlery holder, to avoid silvering and rust spots on stainless steel.

5. Insert the cutlery holders to the basic dishwasher baskets.
6. Before starting the washing process, slide the appropriate basket with tableware into the appliance.
7. Close the appliance door.

Program Selection and Program Start-up

1. By repeatedly pressing the **Program selection** key (3) or **Special program selection** key (2), select a washing program, depending on the tableware and the degree of their soiling.

The selected program is shown in the display (Fig. 4).

2. To start the program, press the **Start** key (4).

During the program, the operation LED indicator lights (6) are flashing from top to bottom, progressively.

When the wash program is finished, the indicator light is lit constantly in green (Fig. 5).

NOTE!

Tableware dries faster, when the tableware basket is removed from the appliance immediately after the program is finished.

3. In order to interrupt the washing program earlier, press the **Start** key (4).

Standard Programs

<i>Pr 1</i>	Short program for lightly soiled tableware
<i>Pr 2</i>	Normal program for standard soiled tableware
<i>Pr 3</i>	Long program for heavily soiled tableware
<i>CLE</i>	Appliance auto-cleaning and draining program at the end of a working day
<i>dr</i>	Draining the tank

Automatic Program Start

With this function, the selected program runs immediately after closing the door. If this function is not available in standard, it must be activated in the settings menu beforehand.

To activate this function (Fig. 6):

1. Press and hold the **Start** key (4) with the appliance on and door open until 'AS' is shown in the display.
2. To deactivate the function, press and hold the **Start** key (4) again for five seconds with door open.

Bottom Sieve Removal

1. Rotate the lower wash arm perpendicular to the appliance door (Fig. 7).
2. Remove both sieves from the bottom of the wash-tank.

Draining the Appliance

1. Remove the bottom sieves (Fig. 7).
2. Pull the overflow upwards (Fig. 9B).
3. Close the appliance door.
4. Select the **dr** program.
5. Start the program, by pressing the **Start** key (3).

The appliance executes the end cycle with auto-cleaning and switches off at the end.

6. If needed, remove the drain sieve and clean it (Fig. 8C).

Switching the Appliance Off

1. Press the **ON/OFF switch** (1) to switch the appliance off.

Three central segments in the **display** (4) remain on and indicate available voltage.

Regeneration

In the case of dishwashers with built-in water softener and when **rEG** message blinks in the display, it is necessary to execute the regeneration cycle to restore the correct operation of the softening system.

To this end, proceed in the following way (Fig. 11):

1. Empty the dishwasher.
2. Clean the wash-tank, observing indications in Section 6 '**Cleaning**'.
3. Remove the bottom sieve.
4. Open the salt dispenser in the tank.
5. Fill the tank with approx. 250–300 g of regeneration salt (kitchen salt, without additives; grain: 1–2 mm).
6. Close the salt dispenser firmly.
7. Make sure, the overflow is removed.
8. Close the appliance door.
9. Switch the appliance on with ON/OFF key (1).
10. Select the regeneration function by repeatedly pressing the program selection key (3), until **rEG** is shown in the display.
11. Press the Start (4) key to activate the regeneration cycle.

The regeneration cycle starts and lasts for approximately 20 minutes.

Then the appliance switches off automatically.

NOTE!

Do not switch the dishwasher off during the regeneration cycle.

Messages

1. When the **Start** key (4) is pressed for a couple of seconds, one by one, a boiler temperature, wash-tank temperature and number of wash cycles executed by the appliance will be shown.

These pieces of information are shown for a minute and they may be called-up, both, before and during the washing cycle.

2. Press and hold the **program selection** key (3) for a couple of seconds to permanently show, one by one and for all programs, the boiler temperature and wash-tank temperature.
3. To deactivate the function, press and hold the **program selection** key (3) for a couple of seconds.

Overview of Possible Messages

<i>door</i>	Door open	<i>CY</i>	Wash cycles executed
<i>b</i>	Rinsing agent temperature	<i>End</i>	Program end
<i>t</i>	Washing temperature	<i>AS</i>	Automatic program start activated
<i>rEG</i>	Bed regeneration required or in progress	<i>Long</i>	Unlimited washing program
<i>SALT</i>	Add salt	<i>SERu</i>	Service

End of Operation

1. Always drain the appliance at the end of a working day. To this end, observe indication in section 'Draining the Appliance'.
2. Use the main switch to disconnect the electric power supply.
3. Close the external water supply cock.
4. Perform the required maintenance works, observing indications in section 'Maintenance'.
5. Clean the appliance observing description in section 'Cleaning'.
6. If possible, leave the door tilted to prevent generation of unpleasant odours.

6.2 Cleaning and Maintenance

- Before cleaning, disconnect the appliance from the power supply.
- Do not use any sharp or pointed, nor metal implements (knife, fork, etc.). Sharp or pointed implements may damage the appliance, and when in contact with live parts, they may cause electric shock.
- For cleaning, do not use any scouring agents that contain solvents nor corrosive cleaning agents. They may damage the surface.
- Do not use pressurized water for washing the appliance.

EN

Daily Cleaning and Maintenance

At the end of the working day, thoroughly clean sieves, wash arms, as well as other accessories.

Thorough cleaning is the most important condition for maintaining long service life of the appliance. Proper cleaning and disinfection of the appliance is the prerequisite for effective washing of dishes.

NOTE: To ensure that the draining process proceeds correctly with the use of the discharge pump, the drain hose must be located at the appropriate height (not higher than 1 metre).

Operation and Maintenance Instructions

The following should be performed regularly:

1. Check the wash arms to make sure they rotate correctly.
2. Before starting the washing process, always check the levels of salt, rinsing agent and washing agent.

Sieve Group Cleaning

1. At the end of the working day, remove all food left-overs from the appliance.
2. Remove baskets for cleaning and wash them in a warm water with a mild washing agent.
3. Drain the wash-tank observing indications in section '**Draining the Appliance**'.
4. Remove the bottom sieves and drain sieve from the dishwasher and clean them thoroughly.
5. Rinse the water tank with warm water, using gentle washing agent and a soft cloth.
6. When all works are finished, refitting the removed elements in the appliance:

Wash Arms Cleaning

To execute regular nozzle cleaning and remove any possible clogs and/or deposits, the wash arms may be easily removed.

Proceed in the following way (Fig. 10):

1. Loosen the fixing groove or make it pop out (appliances with snap lock).
2. Remove wash arms.
3. Wash the wash arms under running water.
4. Clean the nozzles thoroughly, using a toothpick, needle or any other small implements to this end.
5. Clean wash arm spigots in the appliance and in the area of washing and rinsing water outlet.
6. After cleaning, fix the arms again and make sure that they rotate freely.

Technical Service Maintenance

Twice a year, a technical service should carry out the following inspections:

- water filters cleaning;
- descaling of heating resistors;
- checking the condition of gaskets;
- checking the condition of all other components;
- setting of dosing devices;
- checking of electrical connectors;
- checking of power cord.

ATTENTION!

To prevent hazards, a defective power cord may be replaced only by the qualified electrician while observing all safety measures.

6.3 Indications and Tips

Dishwasher Cleaning Agent and Rinsing Agent

ATTENTION!

Usage of incorrect dishwasher cleaning agent and rinsing agent may damage the appliance.

Use only special cleaning agents designed for dishwashers intended for professional use.

Do not use any foaming dishwasher cleaning agents.

Do not use any dishwasher washing agents, which are indented for household use only.

We recommend Bartscher F10LXTRA dishwasher washing agent (art. No. 173271) and Bartscher F10L rinsing agent (art. No. 173272).

When the type of rinsing or washing agent it is necessary to introduce new settings. The settings may only be introduced by qualified technical personnel.

CAUTION!

When in contact with chemical substances, follow suitable safety instructions.

When in contact with chemical substances always wear safety clothing, safety gloves and safety glasses.

Do not mix cleaning agents with one another.

Hygiene Regulations

- Do not touch clean dishes with dirty or greasy hands to avoid soiling dishes.
- For final drying of dishes use clean, sterile towels.
- We recommend using the appliance always after reaching the optimum temperature to ensure that washing also produces optimum results.
- Drain the wash-tank at least twice a day or every 40/50 washing cycles.

Optimum Results

To obtain optimum results during washing dishes, we recommend to proceed the following way:

- Wash dishes only when the appliance is ready for work.
- Dosing devices must always be properly set.
- Always keep the dishwasher properly clean.

Periods of Non-Operation

If the appliance is not used for a longer period (holidays, interruptions at work etc.), follow the instructions below:

- Fully drain the appliance, including the boiler.
- Thoroughly clean the appliance.
- Leave the dishwasher door open.
- Close the water supply valve.
- Switch the main power switch off.
- If there is a risk of frost, order the protection of the appliance against frost to proper technical service.

7 Possible Malfunctions

The table below contains descriptions of possible causes and solutions to malfunctions or errors during operation of the appliance. When malfunction cannot be removed, contact the technical service.

In such a case, provide article number, model name and serial number. These data may be found in the rating plate.

Problem	Description and Possible Solutions
<i>Er01</i>	Rinse program did not start The rinse program did not start correctly. Check the rinse nozzles and clean if necessary.
<i>Er02</i>	No water drainage Water is not draining from the appliance or is draining incorrectly. Check the drain hose for bends and kinks and the water trap and filter for clogging. In appliances with an overflow, the overflow must be removed before starting the final cycle.
<i>Er03</i>	Rinse temperature fault The boiler has not been reheated to operating temperature during the washing process or during the specified time. Switch the appliance off and start a new program.
<i>Er04</i>	Wash-tank water supply fault Check water connections of the appliance and make sure that the water supply valve is open. If applicable, check whether the overflow is in place. Switch the appliance off and refill the water supply.
<i>Er05</i>	Wash-tank thermometer fault (probe open) The appliance does not measure the temperature in the wash-tank. Switch the appliance off and on again.
<i>Er06</i>	Wash-tank thermometer fault (probe short circuit) The appliance does not measure the temperature in the wash-tank. Switch the appliance off and on again.
<i>Er07</i>	Boiler thermometer fault (probe open) The appliance does not measure the boiler temperature. Switch the appliance off and on again.
<i>Er08</i>	Boiler thermometer fault (probe short circuit) The appliance does not measure the boiler temperature. Switch the appliance off and on again.

Possible Malfunctions

<i>Er 09</i>	Boiler filling time-out The boiler was not filled. The rinse program does not start. Check whether the water supply valve is open. Switch the appliance off and on again, and start a new program.
<i>Er 21</i>	Insufficient water volume for the rinse program The rinse program was carried out with too little water. Check the rinse nozzles and clean if necessary. Unit operation is not interrupted.
<i>Er 22</i>	Resetting the wash-tank temperature fault The boiler has not been reheated to operating temperature during the washing process or during the specified time. Switch the appliance off and start a new program.
<i>Er 5F</i>	Electromechanical safety The boiler safety thermostat or tank safety pressure switch has tripped.
<i>Er 5L</i>	Filling level safety The water level in the wash-tank is not correct.
<i>dr t</i>	Sieve contaminated The water level in the wash-tank is not correct. The sieve is dirty or the overflow is incorrectly inserted.
ATTENTION! The messages are reset when the appliance is switched on and off. If the actions described above are preformed and, nevertheless, the problem still persists, contact the authorised service.	

8 Disposal

Electrical Appliance

	<p>Electric appliances are marked with this symbol. Electrical appliances must be disposed of and recycled in a correct and environmentally friendly manner. You must not dispose of electric appliances with household waste. Disconnect the appliance from the power supply and remove power cord from the appliance.</p>
-----------------------------------------------------------------------------------	-----------------------------------------------------------------------------------------------------------------------------------------------------------------------------------------------------------------------------------------------------------------------------------------------------------------------------

Electrical appliances should be returned to designated collection points.